

CRAZY FOR COLOR! • JAZZ UP YOUR KNITTING!

Interweave

Spring 1998

Knits

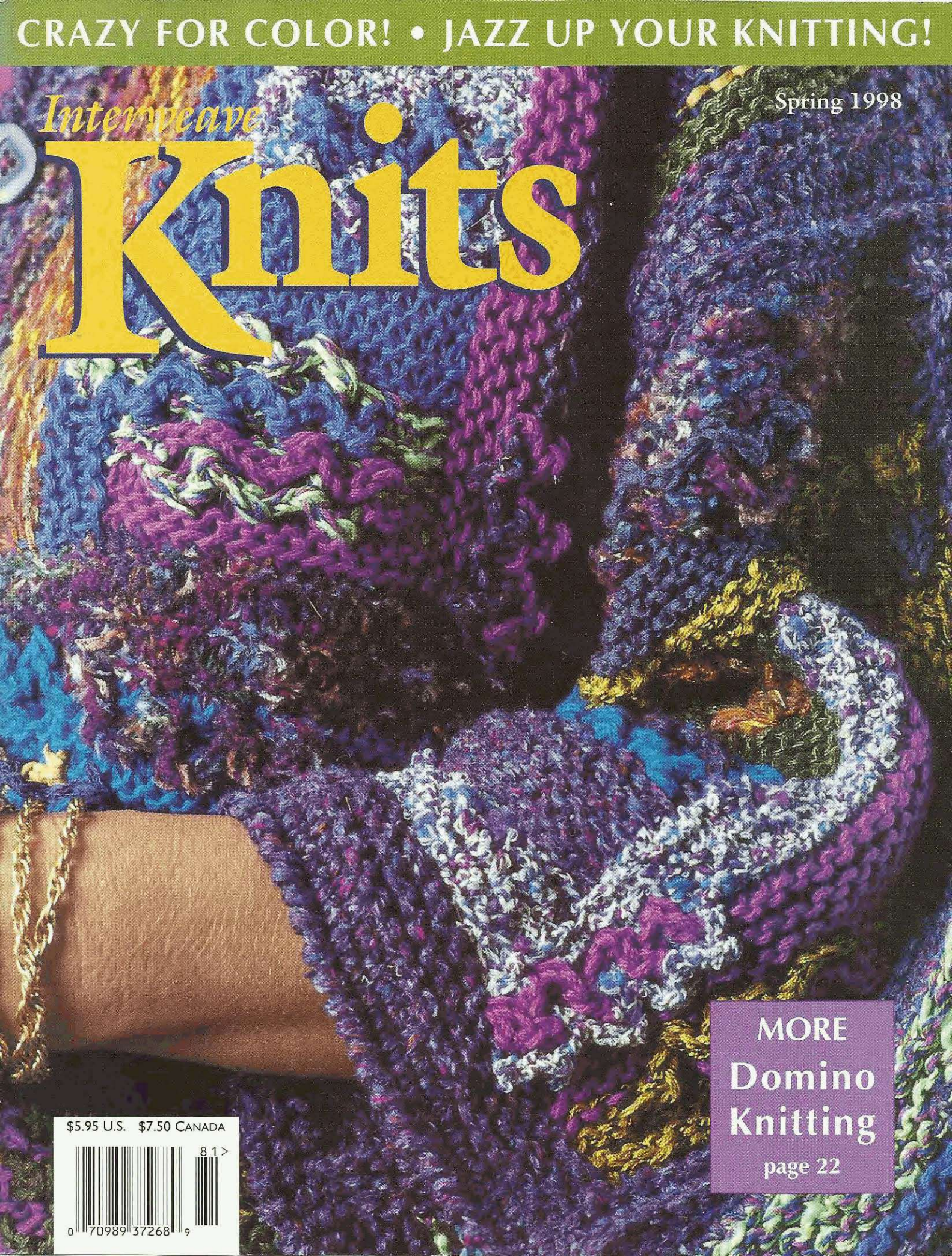

MORE
Domino
Knitting
page 22

\$5.95 U.S. \$7.50 CANADA



0 70989 37268 9

L'Atelier

SANTA MONICA (310) 394-4665
REDONDO BEACH (800) 833-6133

Got Yarn?

Interweave Knits

SPRING 1998
VOLUME III, NUMBER 1

Features & Projects

- 8 A Weekend with Valentina Devine KERSTIN NELSON
- 10 Creative Knitting:
The Kaleidoscopic World of Valentina Devine
- 18 Garter-Stitch Gymnastics Vest ANNE MORGAN JEFFERSON
- 22 Domino Shells: Step-by-Step VIVIAN HØXBRO
- 26 Domino Shells Top and Jacket VIVIAN HØXBRO
- 31 Mayan Socks JEAN MOSS
- 34 Yarn Collector's Sweaters SHARON O'BRIEN
- 38 Yarn Collector's Pillows SHARON O'BRIEN
- 40 Stained-Glass Tunic SARA SWETT
- 46 Green Mountain Madness JUDITH DURANT
- 48 Muted Musician Gansey BETH BROWN-REINSEL
- 56 Tartan Pullover CHERYL OBERLE
- 60 Parfait Sundress LESLIEANN BESTOR
- 71 Knitting Slumber KNITS STAFF

Yarn Collector's Pillows
page 38



Mayan Socks
page 31

Stained-Glass
Tunic
page 40

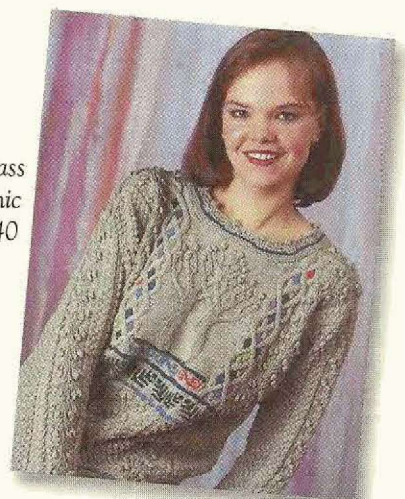

FRONT COVER:
Creative Knitting Rhapsody in Blues Jacket, Valentina Devine

Departments

- 2 Strands
FROM THE EDITOR
- 4 Cables
LETTERS FROM OUR READERS
- 6 Glossary
- 7 Oops
- 54 In the Round
FROM THE HEART
NANCY L. MACKABEN
- 64 Connections
KNITTING IN JAPAN
PATRICIA BARON
- 68 Folk Lore
MONEY CATS, KNITTY KITTIES
ROBIN HANSEN
- 70 Sources for Supplies
- 73 Product News
JILLIAN MORFNO
- 74 Advertisers' Index
- 80 Ravelings
TRAVELLING STITCHES
LINDA LIGON

STRANDS

FROM THE EDITOR



drive past farmland on my way to the office. It is January and the land is barren, the only color the neutral shades of dried grasses. But in just a few months, these fields will be transformed. The earth will be tilled, seeds planted, and soon green shoots will sprout. The earth will burst forth in visually stimulating colors and textures. I think about this change of seasons in relation to this issue of *Knits*, likening the creative process to the advent of spring. One starts with the seed of an idea, allows it to germinate, and molds and shapes it into reality. As knitters, we begin by pulling out the material we create with—our yarn in all its glorious textures and colors.

For me, yarn selection is intuitive. I sit in the middle of the floor, surrounded with yarn, and delve into my stash, grabbing colors and textures that blend harmoniously. It's not only a visual response but a tactile one; considering the hours it takes to knit a project, the feel of a yarn as it flows through my hands, as well as its feel on the body, is as important as how it will look. With knitting needles in hand, I swatch this yarn and that one until the combination is just right.

I think Valentina Devine's approach to knitting exemplifies the word "creativity".

Looking to the landscape for inspiration, her Rhapsody in Blues jacket on page 11 depicts the Southwest sky at sunset. With embellishment, she builds on the surface just as a painter builds with oil on canvas. Shaton O'Brien's sweaters are also tributes

to the natural world. In her article, "Yarn Collector's Sweaters" on page 34, Sharon tells how her inspirations guide the gentle shades and blends of yarn into works of art. Through the use of pattern stitches and innovative techniques, Vivian Høxbro outdoes herself with domino knitting in shell shapes. And Sarah Swett's Stained-Glass Tunic is a stunning example of combining color and texture at will.

We've also considered the use of hand-painted yarns in this issue. In "Green Mountain Madness" on page 46, we get a peek at Cheryl Potter's special contribution to our knitting world—the painting of yarn as a creative venture. Designing with hand-painted yarns can be challenging, but I think you'll agree that our designers are up to this task. Check out Beth Brown-Reinsel's Muted Musician Gansey, Cheryl Oberle's Tartan Pullover, and Anne Morgan Jefferson's Garter-Stitch Gymnastics Vest.

I hope that inspiration may blossom for you this spring.

Marilyn Murphy

In the next

Knits

One Size Doesn't Fit All
Upsizing for the fuller figure
Short-rowing for better fit

Variations on a Theme
One stitch, many shapes
One style, many sizes

Versatile Banker's Vest
Simple designing on the needles

EDITORIAL

EDITORIAL DIRECTOR Linda Ligon EDITOR Marilyn Murphy ASSOCIATE EDITOR Judith Durant ASSISTANT EDITOR Ann Budd PRODUCTION EDITOR Mona Pompili
TECHNICAL EDITOR Dorothy T. Ratigan EDITORIAL ASSISTANT Amy C. Clarke COPY EDITOR Stephen Beal KNITTER Lois Hellmanson

PUBLISHING

PUBLISHER Logan Chamberlain ASSOCIATE PUBLISHER Jillian Moreno
ADVERTISING Jan Hogestad, Shaton Altergott, Terri Stille CIRCULATION MANAGER Jenny Fish

ART & PRODUCTION

DESIGN Elizabeth R. Mrofka PRODUCTION Marc McCoy Owens, Shelly Leuer, Andy Webber ILLUSTRATION Gayle Ford, Susan Strawn Bailey
PHOTOGRAPHY Joe Coca PHOTOGRAPHIC ASSISTANT Lisa Rabold

Interweave Knits (ISSN 1088-3622) is published quarterly by Interweave Press, Inc., 201 East Fourth Street, Loveland, Colorado 80537-5655. Phone (970) 669-7672. Fax (970) 667-8317. Application to mail at Periodicals Postage rates is pending at Loveland, CO 80538, and additional mailing offices.

Interweave Knits is copyrighted © 1998 by Interweave Press, Inc. All rights reserved. Reproduction in whole or in part is prohibited, except by permission of the publisher. Printed in the USA. For subscription information, call (800) 645-3675. Visit the Interweave Press web site at: <http://www.Interweave.com>.

INTERWEAVE PRESS

Distributed by WARNER PUBLISHER SERVICES
A TIME WARNER COMPANY

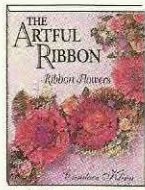

93-4340. \$25.95/\$21.95
Softcover

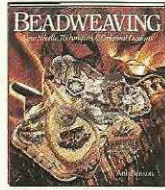

54-0863. \$24.95/\$19.95

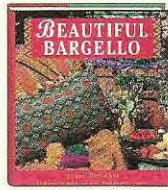

38-3324. \$29.95/\$25.50



33-6182. \$22.95/\$18.95



23-7312. \$24.95/\$19.95

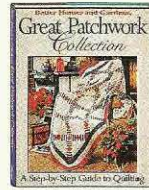

16-0726. \$29.95/\$25.50



65-7127. \$27.95/\$22.95



52-8210. \$24.95/\$21.95



75-7240. \$27.95/\$22.50

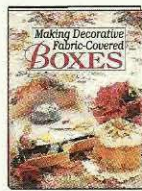

55-0760. \$24.95/\$19.95

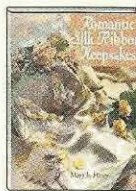

56-0674. \$27.95/\$22.50

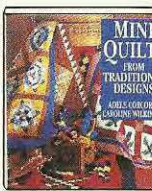

24-8799. \$24.95/\$20.95



44-8600. \$29.95/\$25.50

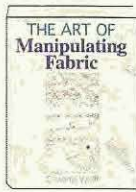

33-0048. \$29.95/\$25.95
Softcover

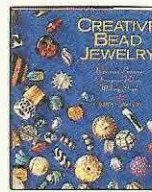

55-0205. \$27.95/\$25.50

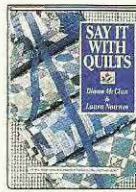

66-2818. \$29.95/\$24.95



83-5142. \$27.95/\$25.50

▼ 56-1452/99-9999. \$35/\$27.95
Counts as two choices*

▼ 78-5617. \$27.95/\$23.50

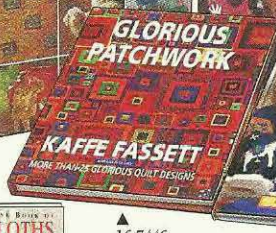

26-5310. \$29.95/\$24.95

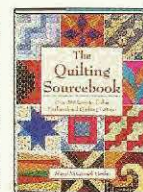

18-3522. \$29.95/\$24.95

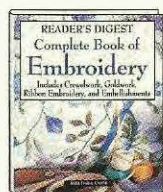

96-1087. \$25/\$20.95

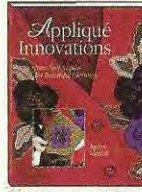

98-5393. \$27.95/\$23.50

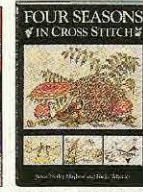

65-7586. \$24.95/\$20.95

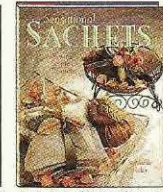

45-7584. \$27.95/\$23.50



96-6353. \$29.95/\$24.95

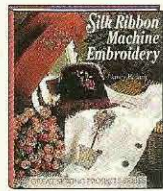

16-2766. \$27.95/\$23.50

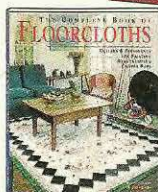

53-7774. \$24.95/\$20.95

▲ 16-7446. \$30/\$25.50

▲ 44-1681. \$22.95/\$19.50

Pub. price/Club price



Crafter's Choice®

A Division of Book-of-the-Month Club, Inc. Camp Hill, PA 17012-0001

Take 3 books for \$1 each as a member of Crafter's Choice.

YES! Please enroll me in Crafter's Choice according to the terms described at the left.

Indicate your book choices by number: - - 8-38

*To order a "Counts as two choices" book, write the 6-digit item number in one box and "99-9999" in the next.

Special Offer: Select a 4th book at 50% off the publisher's price now, plus shipping and handling. Then buy just one more book during the next year.

4th book at 50% off (optional):

CCBC2-4-0

Name
(Please print clearly)

Address Apt.

City State Zip

GUARANTEE OF SATISFACTION: You may examine your introductory books for 10 days, free. If you are not satisfied, for any reason whatsoever, simply return the books and you will be under no further obligation.

My main interest is (check one box only) but I am free to choose from any category:

- Sewing (1)
- Quilting (2)
- Cross-Stitch (5)
- Naturecrafts (4)
- Decorative Woodcrafts (5)
- Needlecrafts/Stitchery (6)
- Knitting (7)
- Other (8)

Have you purchased anything through direct mail?
 Yes No

How do you pay for your mail-order purchases?
 Cash Credit Card Check
 Money Order

How many books have you purchased in the past year?
 None 1 to 5 6 or more #077

Sewing • Knitting • Quilting •
Naturecrafts • Needlework •
Stenciling and much more....
Whatever craft you like to do,
Crafter's Choice has the best
books for you.

Become a member today by choosing 3 books for \$1 each. Enjoy your books for 10 days. If you're not satisfied, return them to us. You'll owe nothing and be under no further obligation. Otherwise, we'll bill you \$1 for each, plus shipping and handling. You simply agree to buy 2 more books within the next year, but you may buy as many as you wish.

As a member, you'll receive the Crafter's Choice Collection 17 times a year (about every 3 weeks). Each issue describes a Main Selection considered by our editors to be one of the best newly published crafts books, plus scores of other books and related products at prices up to 20% lower than the publishers', and up to 50% lower with special offers in every catalog. If you want the Main Selection, do nothing. We'll send it to you automatically. If you want other books—or no books—indicate your decision on the Reply Card and return it by the specified date. Best of all, every purchase earns you valuable Bonus Points that you can trade in for FREE books. A shipping and handling charge is added to each shipment. If the Collection is delayed and you receive a Main Selection without having had 10 days to notify us, just return it and owe nothing. Your membership may be discontinued by you or by the Club at any time after you've bought 2 additional books within the next year.



Crafter's Choice® is a registered trademark of Book-of-the-Month Club, Inc., and includes Better Homes & Gardens® Crafts Club, a registered trademark of Meredith Corporation.



Prices and offer may differ in Canada.
All orders subject to approval.
©1998 BOMC

CABLES

LETTERS FROM OUR READERS

INSPIRE ME

I enjoy projects that spark my imagination with new and unusual applications of the knitting basics. I'm especially excited about sweaters that are knit in unusual ways—cuff to cuff, diagonally, in squares and stripes, etc. I'd also appreciate some articles that focus on novelty yarns. I am always captured by these yarns but disappointed in how they look knitted up—the yarns always seem to lose their magic and turn "stripey" or obscure the pattern stitches. And how about some projects designed with variations—cardigan or pullover, collar or not, a pattern that could be placed on the bottom or at the yoke, etc.

Philosophically, I want to see knitters learn to be more creative and not feel locked in to exactly reproducing someone else's idea. Anything you could do to further this would be a great service to the craft.

Kay Wienecke
Williamsport, Pennsylvania

Great timing, Kay! Look to pages 8–15 for Valentina Devine's creative knitting and use of novelty yarns, pages 18, 48, and 56 for garments that incorporate handpainted yarns, and the Yarn Collector's Sweaters on page 34. The upcoming Summer 1998 issue of Interweave Knits will feature several garments with design variations.

DOUBLE TAKE

I was happy to see your article on double knitting in the Fall 1997 issue of *Interweave Knits*. However, I was truly disappointed that no mention was made of Beverly Royce's *Notes on Double Knitting*. You state that the simplest form of double knitting is done with two balls of yarn. I disagree—the simplest form of double knitting is done with one ball. Had I been faced with two balls of yarn when learning this wonderful technique I would have felt daunted from the start. Beverly Royce was my introduction to this delightful challenge and her book includes every possible technique, progressing from the easiest to the most exotic and difficult applications.

Julie V. Ouseley
Rome, Georgia

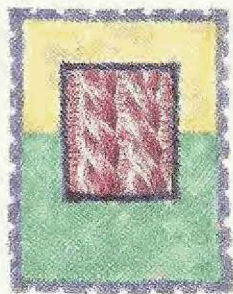

Our apologies for this oversight. Notes on Double Knitting, published by Schoolhouse Press 1981, offers extensive information on double-knit tubes.

DIFFERENT STROKES

The format for your magazine is a lot like all the other knitting magazines—directions for knitted projects. If you like one of the projects in an issue well enough to make it, great; if not, there isn't much value in that issue. I'd like to see a more technique-oriented format that includes information that would be useful regardless of the project you're working on. Please consider such topics as different approaches to designing, choosing yarn, knitting, finishing and blocking, unusual techniques, and troubleshooting.

Holly Prentice
Acton, Massachusetts

Thank you for putting together a very stimulating magazine dedicated to the forward-thinking craftsperson. I've been searching fruitlessly for several years for a publication such as yours, having conquered basic techniques and patterns. I no longer dread the search for an engaging knitting project.

Dari Stolzoff
Seattle, Washington

Appealing to all levels of knitters is always a challenge. We continually strive for a balance between strong technical articles and projects.

FINE NEEDLES

The Winter 1997 issue featured a needle review that was much needed. While I understand that for regular knitting the U.S. sizes 2–8 are most commonly used, I am disappointed that no mention was

made of finer needles, especially those from 0–4×0. The U.S. only produces down to 0 (2mm), but Germany still manufactures needles as fine as 4×0 and Laci's has handmade 5×0 to 8×0. These are used for fine yarn knitting, lace knitting, charted needle design and machine embroidery techniques.

Kaethe Kliot
Berkeley, California

Unfortunately, we often face space constraints when producing an issue of Knits, and for that reason we did limit the scope of the needle review. We are familiar with (and indeed many of us use) the fine needles you mention. The omission was in no way disparaging.

BORN AGAIN LACE KNITTER

I was given a copy of *Interweave Knits*, Spring 1997 as a gift. I had just returned to knitting Shetland lace after a twenty-year absence. As I had also been given Susanna Lewis's book *Knitting Lace* (Taunton Press, 1992) a few months earlier, the desire to knit lace was reborn. Since then, I have designed twenty-four bonnets, caps, and mop caps in #30 and #20 cotton 1-ply Shetland lace wool and 1/32 silk. I have made them from the very simple silk border garter stitch to the Mrs. Belli's Diamond Edging that was featured in *Knits*.

Catherine M. Thomson
Victoria, B.C., Canada

SEARCHING

I own an antique sock knitting machine and am searching for an instruction booklet. Does anyone have information on this machine? It's a Gearhart's 1914 Knitter, with ribbing attachment, manufactured by Gearhart Knitting Machine Co., Clearfield, Pennsylvania. If you know anything about this machine, please contact me directly.

Sharon Cuyler, 1750 W. Tienken Rd.,
Rochester Hills, MI 48306 ☞

We welcome your comments and questions. Write to "Cables", Interweave Knits, 201 East Fourth Street, Loveland, CO 80537-5655; fax (970) 669-6117.

MORE FINE BOOKS FROM TAUNTON

Inspiration from the experts!

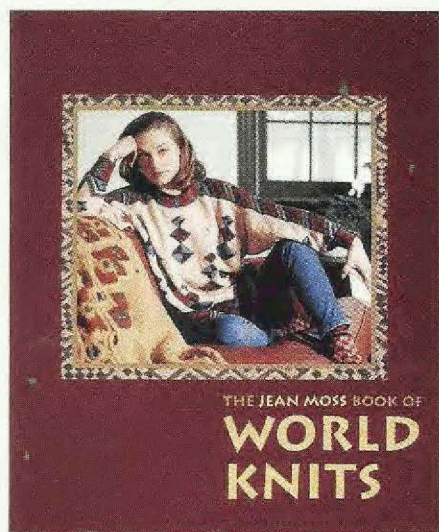

NEW!

The Jean Moss Book of World Knits by Jean Moss
Internationally known knitwear designer Jean Moss offers unique designs for sweaters, hats, socks and soft furnishings. Includes 35 designs with detailed instructions and charts. Each is based on a traditional textile which Moss shows with her patterns. Blends the richness of tradition with the finest fashions.

HARDCOVER, COLOR, 128 PAGES, 47 PHOTOS, 83 DRAWINGS,
ITEM 070330, \$27.95

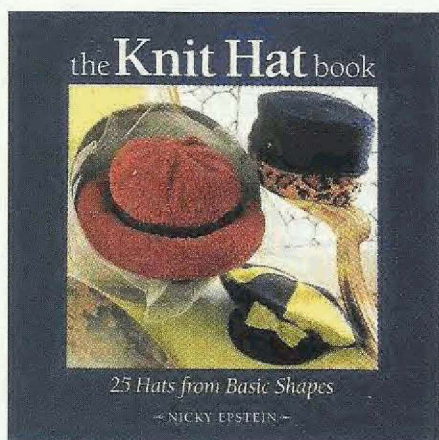
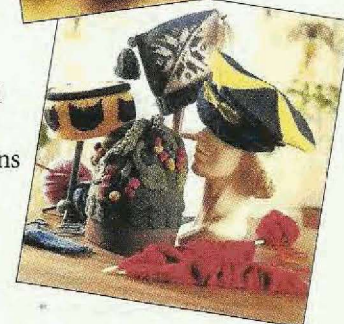

NEW!

The Knit Hat Book by Nicky Epstein
The perfect small-project book for knitters. Popular knitwear designer Nicky Epstein gives knitters of all skill levels a wide variety of stylish hat projects. Includes 25 patterns plus the techniques to create and knit hat designs of your own.

SOFTCOVER, COLOR, 112 PAGES, 30 PHOTOS, 15 DRAWINGS,
ITEM 070329, \$19.95

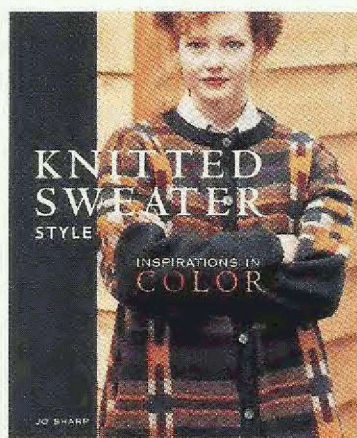
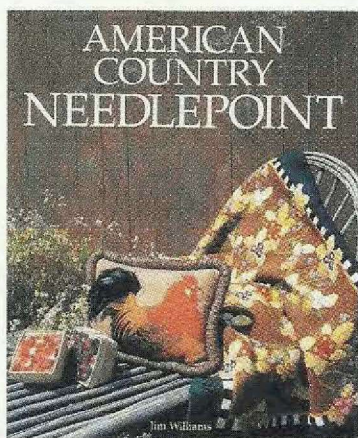

American Country Needlepoint

by Jim Williams

An inspiring collection of nostalgic needlepoint patterns that all needlecrafters will find fun and rewarding. Charming projects combine country themes with new techniques and materials. You'll find distinctively different projects and full directions for assembling the piece on completion.

SOFTCOVER, COLOR, 112 PAGES, 32 PHOTOS, 46 DRAWINGS,
ITEM 070300, \$24.95

Knitted Sweater Style

by Jo Sharp
This full-color, illustrated book provides 42 original knitting patterns and designs for outstanding sweaters. These designs for men, women and children are easy to duplicate and encourage all knitters to experiment with colors and textures. A great starting point for your own sweater designs.

HARDCOVER, COLOR, 128 PAGES, 71 PHOTOS, 87 DRAWINGS,
ITEM 070309, \$27.95

To order call 1-800-888-8286,
operator W666, or visit our website
at www.taunton.com



TAUNTON BOOKS

Glossary

Abbreviations

alt	alternate
BC	back cross
beg	beginning; begin; begins
bet	between
BO	bind off
CC	contrasting color
cm	centimeter(s)
cn	cable needle
CO	cast on
cont	continue
dec(s)	decrease(s); decreasing
dpn	double-pointed needle(s)
FC	front cross
fol	following
g	gram(s)
inc	increase; increasing
k	knit
k tbl	knit through back of loop
k2tog	knit two stitches together
kw	knitwise
LC	left cross
LT	left twist
m(s)	marker(s)
MC	main color
mm	millimeter(s)
M1	make one
p	purl
patt(s)	pattern(s)
pm	place marker
psso	pass slip stitch over
p2tog	purl two stitches together
pw	purlwise
RC	right cross
rem	remaining
rep	repeat
rev St st	reverse stockinette stitch
rib	ribbing
rnd(s)	round(s)
RS	right side
RT	right twist
sc	single crochet
sk	skip
skp	sl 1, k1, psso
sl	slip
sl st	slip stitch (sl 1 st pw unless otherwise indicated)
ssk	slip, slip, k 2 sl sts tog
st(s)	stitch(es)
St st	stockinette stitch
tbl	through back loop
tog	together
WS	wrong side
wyb	with yarn in back
wyf	with yarn in front
yo	yarn over
*	repeat starting point (i.e., repeat from *)
**	repeat all instructions between asterisks
()	alternate measurements and/or instructions
[]	instructions that are to be worked as a group a specified number of times

Knitting Gauge

To check gauge, CO 30 to 40 sts using the recommended needle size. Work in pattern stitch until the piece measures at least 4" (10 cm) from the cast-on edge. Remove the swatch from the needles or BO loosely, and lay the swatch on a flat surface. Place a ruler over the swatch and count the number of stitches across and number of rows down (including fractions of stitches and rows) in 4" (10 cm). Repeat two or three times on different areas of the swatch to confirm your measurements. If you have more stitches and rows than called for in the instructions, use larger needles; if you have fewer, use smaller needles. Repeat until the gauge is correct.

Reading Charts

Unless otherwise indicated, charts are read from the bottom up. On right-side rows, read charts from right to left. On wrong-side rows, read charts from left to right. When knitting in the round, read charts from right to left for all rows.

Kitchener Stitch

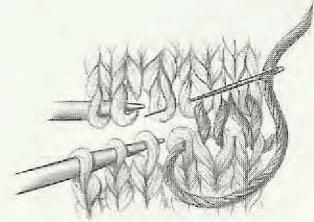

1. Bring yarn needle through the front st as if to purl, leaving the stitch on needle.
2. Bring yarn needle through the back st as if to knit, leaving the stitch on needle.
3. Bring yarn needle through the same front st as if to knit, and then sl this st off needle. Bring needle through the next front st as if to purl, again leaving the st on needle.
4. Bring yarn needle through the first back st as if to purl, sl that st off, and then bring yarn needle through the next back st as if to knit, leaving it on needle. Rep steps 3 and 4 until no sts remain.

I-Cord

With dpn, CO desired number of sts. *Without turning the needle, slide the sts to the other end of the needle, pull the yarn around the back, and knit the sts as usual; rep from * for desired length.

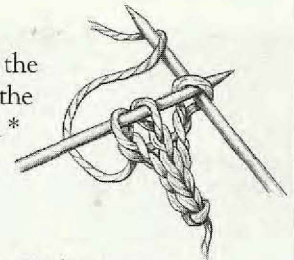

Applied I-Cord

As I-cord is knitted, attach it to the garment as follows: With garment RS facing and using a separate ball of yarn and cir needle, pick up the desired number of sts along the garment edge. Slide these sts down the needle so that the first picked-up st is near the opposite needle point. With dpn, CO desired number of I-cord sts. Knit across the I-cord to the last st, then knit the last st tog with the first picked-up st on the garment, and pull the yarn behind the cord (pull the yarn in front of the cord for reverse I-cord). Knit to the last I-cord st, then knit the last I-cord st tog with the next picked-up st. Cont in this manner until all picked-up sts have been used.

Note: When working applied I-cord, as in all picked-up edge finishes, do not pick up every st. Work the edging for about 2" (5 cm), then lay the piece flat to make sure that the cord lies flat along the edge—if not, pull out the necessary sts and rework, picking up more or fewer sts along the garment edge, as needed.

Binding Off Shoulder Seams Together

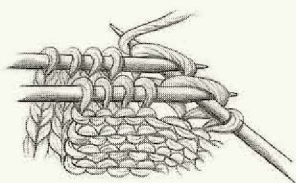

Place the front and back shoulder stitches onto two separate needles. Hold them in your left hand with the right sides of the knitting facing together. In your right hand, take another needle and insert the right-hand needle into the first stitch on each of the left-hand needles and knit them as one stitch. Knit the next stitch the same way. You now have two stitches on the right-hand needle. Pass the first stitch over the second stitch. Repeat until only one stitch remains on the right-hand needle. Cut the yarn and pull the tail through last stitch.

OOPS!

Corrections to the Winter '97 issue:

A Quick Double-Knit Hotpad! (page 18) and Bobby's Blankie (page 28): The star motif chart A is missing the center square. Here is the corrected chart.

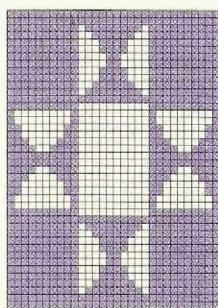

Bobby's Blankie (page 28): The fourth sentence of the second paragraph should read: Work 20 sts, pm, work 120 sts reversing colors, pm, work 20 sts reversing colors.

Ribbons and Snowberries (page 35): The second sentence of the second paragraph should read: *Set-up row:* (WS) K16 (21, 26, 31), pm, p20, [k4, p1] 3 times, k4, pm, p20, k16 (21, 26, 31).

Corrections to the Fall '97 issue:

Talisker Cardigan and Tam (page 56): The markings on where to begin and end the sizes on the charts are incorrect. Below are the corrected markings.

Talisker Cardigan and Tam (page 59): Round 2 of the Tam instructions should read: (Dec rnd) Sl 2 sts kwise (the last st of Rnd 1 and the first st of Rnd 2), k1, p2sso, *p3, k1, p4, k1, p3, sl 2 kwise, k1, p2sso; rep from *, end p3, k1, p4, k1, p3.

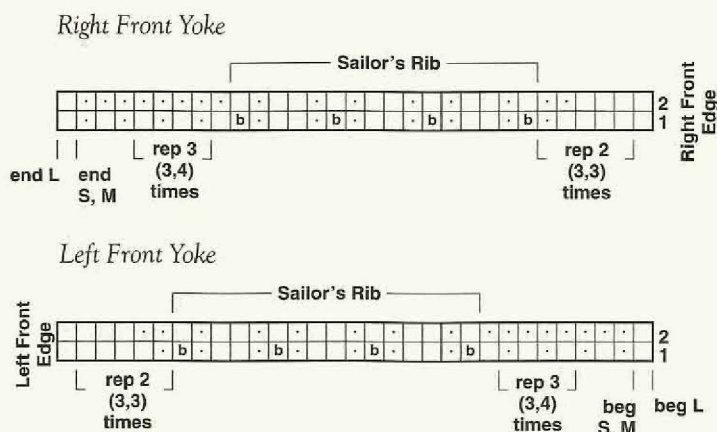

new Spring '98

Delightful and witty designs featuring Tahki's family of favorite classic cottons, COTTON CLASSIC, CLASSIC COTTON DOT and NEW TWEEDY COTTON CLASSIC.

For your copy of Picture Perfect Kids, Vol.1 or Classic Cottons, Vol.1 and the shop nearest you send a check or money order for 6.99 each book to:
Tahki Yarns, Dept. IS98
11 Graphic Place, Moonachie, NJ, 07074



TAHKI YARNS are available at fine shops everywhere

A Weekend with Valentina Devine

Kerstin Nelson



“I’M NOT a retired bubble dancer,” Valentina Devine says to her students. “And I didn’t make up my name.”

Valentina is a svelte grandmother who has come to California to present a weekend workshop in creative knitting to the Santa Barbara Fiber Arts Guild. Her own best advertisement, she is wearing a man’s black vest to which she has added entrelac sleeves knitted in descending tones of gray on a black background, rhinestone buttons, and a lace-edged handkerchief discretely tucked into the watch pocket. Teamed with a pearl gray sueded silk skirt, the look is elegant.

Valentina stands beside a table laden with more examples of her work—sweaters, coats, and vests—all in vibrant colors, all composed of knitted geometric forms. Two other tables, each eight feet long, are heaped with yarn in every imaginable weight, texture, and color—all hand-dyed by the artist. She picks up a pair of knitting needles and a ball of her variegated yarn—marvelous shades of orange, red, and yellow. “Now we will start.” Each word is carefully enunciated. Her voice still has a trace of a German accent and her syntax takes a little getting used to. “Cast on not more than fifteen stitches and start knitting.” Sixty-plus knitters of all ages,

shapes, and sizes do exactly as she says. As we concentrate on our knitting, Valentina tells us something of her life.

The daughter of a Russian mother and German father, she was born in Moscow and raised in pre-World War II Berlin—the wrong time to be anything but pure German. “There were no Valentinas in Germany, let me tell you,” she recalls. “During that time I was called Walli and I was forbidden to speak Russian.”

After the war, when Berlin was divided, the Wall split her neighborhood, but fortunately Valentina’s house was on the Allied side. As a young woman, she was haunted by the Wall’s ominous, silent presence and the sight of abandoned houses in the Eastern sector with their broken windows, some of which had curtains still hanging in them.

Years later, after she had moved to the United States, Valentina was invited to knit a piece for an exhibition. She accepted the challenge. She intended to knit a torn curtain. Beginning with coarse, natural linen thread, she knitted shapes with gaping holes. One day, she flipped one of the pieces sideways and a face with staring eyes looked out at her—the spirit of all those who had suffered persecution and death in the war and post-war era. Her “curtain” became a series of ghostly faces roughly laced together. The piece was a success.

Someone asks when she learned to knit. Valentina explains that learning to knit was a rite of passage for all German girls of

her era; she was no exception. “My mother would say to me, ‘You will knit for an hour. Now.’ I always imagined that she added ‘and you will enjoy it.’”

As our work progresses, Valentina goes from knitter to knitter offering comments on color combinations or the choice of appropriate yarns. She continues to tell us anecdotes from her knitting life, the most memorable of which was what she describes as the Nightmare Sweater.

She and a friend had teamed up and designed a sweater that was included in a national mail-order catalogue. She shudders at the recollection.

“They gave us a large picture in the catalogue and we got many more orders than we expected. Then we had to get more knitters. Some of them smoked. Some of them didn’t know how to handle the gauge. Then we had to get people to properly assemble the pieces, ensuring quality control. Finally we had to send out a form letter to our customers explaining that they would have to wait about two months for their sweaters. The form letters created even more interest and brought more orders. It took us two years to fill them all.”

She shows us a picture of the Nightmare Sweater. It’s a handsome jacket, knitted on the bias with hand dyed yarns. The design is still good and available in kit form or by special order from Yarn Creations, 1222 Big Rock Loop, Los Alamos, NM 87544.

Another time, she tells us, a friend called and said “You’ve got to meet this

artist from England. He's utterly fantastic." It was a rainy day and Valentina was tired. She tried her best to get out of going over to meet this person but her friend was adamant. Finally she gave in and drove to her friend's house where she met Kaffe Fassett for the first time.

"It changed my life forever." The sense of wonder is still in her voice. "I had never really looked at a stone wall before. I had never seen so many shades of gray there. I have not looked at things the same since."

Having Valentina visit our guild is something of a coup. Since being featured in Melanie Falick's instant knitting classic *Knitting in America*, Valentina's lectures and workshops are much in demand.

Today we have visitors from as far north as Cayucos, over a hundred miles away ("We've ditched our husbands and run off to Santa Barbara. You guys have the greatest workshops!") and from as far south as Thousand Oaks, about forty miles away ("Hey, we'd rather come here than go to Los Angeles."). There are enough of us that we have to split into two groups for the individualized instruction part of the workshop.

The technique that Valentina is teaching this weekend is deceptively simple: Knit squares starting with a small rectangle at the center and, working out, build on the original rectangle with different yarns and colors until you have a piece about twelve inches square. Every time you change color, leave a tail of yarn about thirty-six inches long on the front of the piece. These tails will then be used to embellish the finished garment—with crochet, embroidery, beads, shi-sha mirrors, milagros, tassels—whatever you feel like using.

How many squares does a garment take? For a vest, knit eight squares. For a jacket, knit twelve. Then crochet the squares together using a compatible color. That's all.

WHAT KIND OF YARN IS BEST?

"Anything you have in your workbasket. It doesn't matter as long as you think the colors go well together." Valentina's only admonition is that the weight of the yarns should be pretty much the same. Even so, you can combine or double thin yarns to make them equal a fat yarn or throw in a fat yarn for one or two rows as

an accent—just don't let it distort the square shape.

WHAT SIZE NEEDLE SHOULD YOU USE?

It doesn't make much difference but you want the finished product to be "draped, not like a pot scrubber." Valentina warns us that small needles and tight knitting make a sure-fire recipe for pot scrubbers.

She works everything in garter stitch because it forms a perfect square—stockinette stitch will give a rectangle. If you

Valentina put together a wide array of Tahki Yarns for her Rhapsody in Blues jacket shown on page 11.

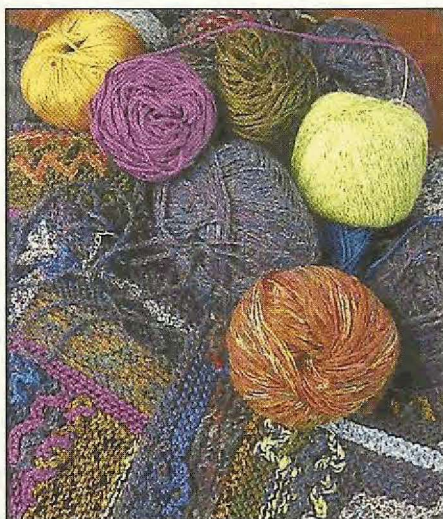

Valentina sells her knitwear and hand-dyed yarns at shows across the country. She's seen here at Taos Wool Market in New Mexico.

get tired of garter stitch you can stick in a few purl stitches "wherever you feel like it. I call this mindless knitting."

The only constant is the size of the squares "about twelve to fourteen inches" and even that can be fudged a little

when you assemble them—just add a couple of crochet rows on one side of the offending square to bring it up to size, then crochet it to the rest of the squares to form the garment.

The next morning we reconvene and begin the day with a detailed examination and explanation of some of Valentina's garments. Seams and buttonholes are scrutinized and she gives us exhaustive information on finishing techniques.

Someone asks Valentina who dyes her yarn for her. "I do it on my stove," she answers. "I use an acid dye that exhausts very quickly." She speaks with the freedom of one who is so good at her craft that she can share all (or almost all) of her secrets.

Late that afternoon, as we are about to finish, Valentina's husband makes an appearance wearing a beautiful sweater knitted by Valentina. He's a physicist who served twenty years with the U.S. Navy.

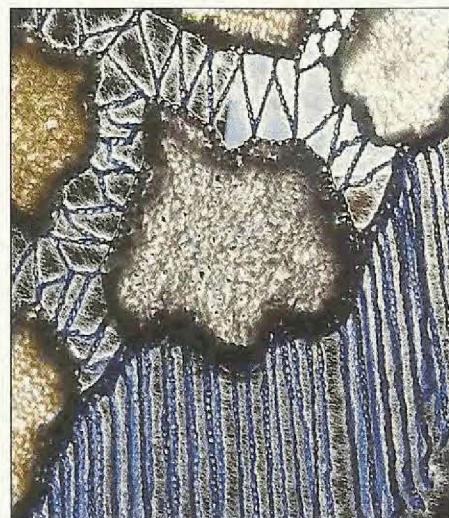

In addition to her one-of-a-kind garments, Valentina creates beautiful, sometimes ethereal fiber sculptures.

He and Valentina now live in Los Alamos, New Mexico where he works for the University of California. He tells me that Valentina, in addition to her knitting, sings and plays the guitar—acoustic, it turns out, but electric would not be out of character.

I'll bet one of her better numbers is "Anything Goes".

Kerstin Nelson is a freelance writer who has been knitting since childhood. She lives in Santa Barbara, California, where she spins her own yarn and designs sweaters.

CREATIVE KNITTING

The Kaleidoscopic World of Valentina Devine

CREATIVE, modular, log cabin, abstract—all these words describe Valentina Devine's knitting. Using a kaleidoscope of colors and textures, Valentina knits rectangles, squares, strips, or triangles and then sews them together into stunning garments which she richly embellishes with crochet or embroidery. Her simple methods will appeal to knitters who like to just pick up their needles and yarn and knit, and the exciting and unpredictable results will appeal to anyone who likes to play with color and texture.

In a nutshell, Valentina begins a shape by knitting with one yarn and then builds on this foundation by changing both the yarn and the direction of the knitting. She knits a bunch of coordinating blocks then puts them all together for vests, sweaters, scarves, or shawls that are bursting with color and texture.

Valentina doesn't claim the technique to be her own, but her color and yarn choices coupled with her unique embellishments identify her work. Creative knitting is a great way to use up odd-ball yarns, but Valentina is quick to add that she never calls these "leftovers". "There is no such thing as leftover yarn—can you imagine a painter calling unused paint 'leftover'?"

CHOOSING YARNS

The success of creative knitting depends largely on the right combinations of colors and textures. Finding an assortment of yarns that "work" can be the most fun or the most excruciating step. To help with selection, Valentina suggests you sort through the yarns in your stash, grouping them by colors as well as weights or gauges that are compatible. If you're unsure whether two yarns will knit up to about the same gauge, feel them side by side between your fingers. They should feel similar but needn't be exactly the same; this technique allows for quite a bit of flexibility. Include yarns of all textures and fibers.

Keep in mind that lighter weight yarns can be doubled or tripled to be compatible with heavier weight yarns. If you've chosen mostly worsted weight yarns, double sport or triple fingering weight and use bulky sparingly; if you've chosen mostly sport weight, double fingering and use worsted sparingly, etc. You can use a fun, chunky yarn for one or half a row; you can also carry a thin strand of yarn throughout. For unity, choose one yarn to be used in each of the squares.

Now make a tight pile of your chosen yarns on a solid-colored surface. Stand back about six to eight feet and evaluate the colors. Appraise the value range from light to dark—is there too much contrast, too little? Play around with the colors, adding and taking away balls of yarn until you find an assortment you like. There is no limit to the number of colors and textures you can combine, and no right or wrong combination—whatever "works" for you is fine. One of Valentina's most popular combinations is of whites and off-whites. One of her trademarks is using many colors bordered in black; each square has a touch of black in it as well.

How do you know how much yarn you'll need? As a rule-of-thumb, allow about two pounds (1 kg) of yarn for a medium-size, medium-weight long-sleeve sweater. A coat-length sweater or larger size may require more.

LET THE KNITTING BEGIN

All you need to know to make one of these squares is how to cast on, bind off, and knit. You can, of course, use purl stitches, but most of the pieces illustrated here are worked in garter stitch. The beauty of garter stitch is that because one stitch is as wide as two rows are long, you can pick up one stitch for each ridge to set up knitting in the opposite direction and know the piece will lie flat. There's very little thinking to do.

Once you have chosen your yarns and the appropriate needle size, choose one yarn (A) to begin. Using your favorite method, cast on five to fifteen stitches and work in garter stitch for about 1½" (3.8 cm).

Now it's time to change yarn. Cut yarn A, leaving about a 36" (1 m) tail. Also leave a 36" tail of your next yarn, B. Place the two tails together and tie them with a loose overhand knot from one to a few inches away from the needle. Continue knitting with yarn A until you come to the knot, drop yarn A, then work with yarn B. This method will ensure that the yarn changes occur in the middle of the row, adding interest to the overall composition.

At this point you'll need to decide which will be the right side of the work. All yarn changes, changes in knitting direction, and binding off are done with the right side of the work facing you. The yarn tails are also left hanging on the right side. Start knitting with B and knit until you want to change to the next color. If you don't like the look of the color transitions in garter stitch—you end up with two-colored stitches—you can purl the stitches where the changes take place and then resume with garter stitch. As you'll see later, you will also have an opportunity to hide these transitions with embellishment.

When you are ready to reverse direction, bind off loosely with the right side facing, but don't break off your yarn. Turn your work 90°, and with the same yarn pick up one stitch for each garter ridge. On the last ridge, pick up the very first cast-on stitch to square off the row. There's absolutely no need to count your stitches.

Continue knitting on the next edge with the same yarn for a few rows, change yarns, and repeat this procedure working four areas around the central block and then building up around each subsequent area to create a log cabin effect. When your square is the appropriate size, bind off the final edge. Continue making squares until you have enough for your chosen project.



EMBELLISHING

Your squares will look pretty messy at this point with all the yarn ends dangling from the right side. You'll use these ends to decorate and finish the squares.

For crocheted embellishment, you need to know single crochet and chain stitch. You can also embellish with embroidery, but Valentina recommends not combining embroidery and crochet in one piece. Beads, buttons, or charms can be added too.

Just pick a pair of yarn tails to start with and unknit them. Separate the two yarns and with right side facing, bring your crochet hook in as close as you can to the attached end of one of them. With that yarn, work a base stitch, chain three, and attach the chain to the square. Continue to chain three and attach to the square, determining the direction as you go. In order to blend your color areas, Valentina advises working the crochet chains into opposite color areas so the colors criss-cross each other; this helps break up hard lines and will also cover unappealing color transitions. When you finish with one tail, pull it through to the wrong side of the square and secure it in place. Continue working all the remaining strands. You can zig-zag, swirl, intertwine colors, make flower petals, create ruffles, or just meander with your stitches.

THE TEST

Once your squares are complete, you have to determine the best orientation for each in the finished garment. Here's how. Stand ten to twenty feet from a mirror and hold a square against your body. Turn the piece until you are satisfied with the balance of the colors. This is the way you should place the piece in the garment. Some squares will look equally good from any angle, some will look best in one orientation. Perform this test on four or five pieces, then place all the pieces on the floor and arrange a final balance.

PUTTING IT ALL TOGETHER

Because you've used yarns of different weights and textures, it is important that you block your squares before assembling them into a garment. If you find one that's a bit smaller than the others, simply pick up stitches and add the necessary width or length.

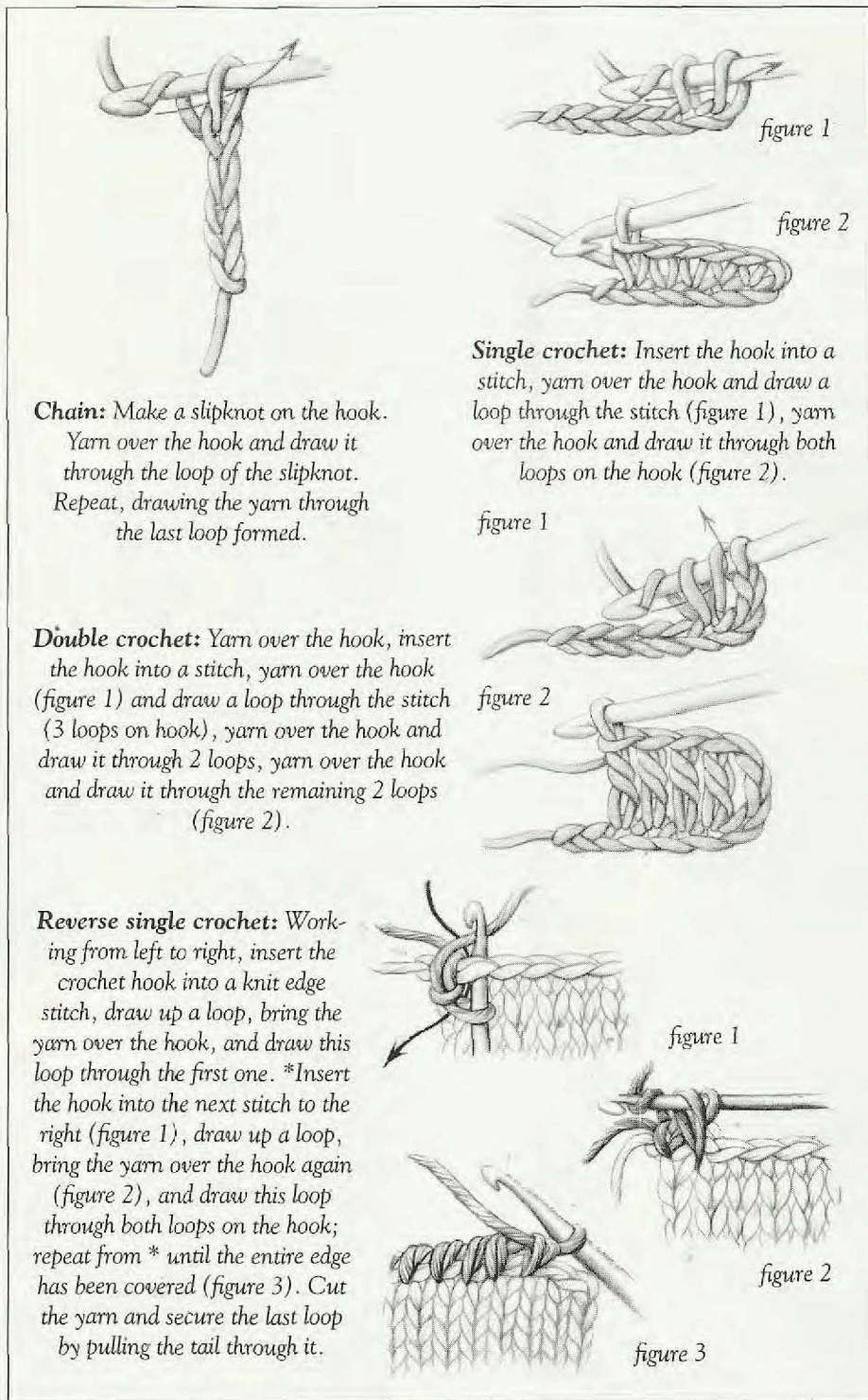

Chain: Make a slipknot on the hook.

Yarn over the hook and draw it through the loop of the slipknot.

Repeat, drawing the yarn through the last loop formed.

Single crochet: Insert the hook into a stitch, yarn over the hook and draw a loop through the stitch (figure 1), yarn over the hook and draw it through both loops on the hook (figure 2).

Double crochet: Yarn over the hook, insert the hook into a stitch, yarn over the hook (figure 1) and draw a loop through the stitch (3 loops on hook), yarn over the hook and draw it through 2 loops, yarn over the hook and draw it through the remaining 2 loops (figure 2).

Reverse single crochet: Working from left to right, insert the crochet hook into a knit edge stitch, draw up a loop, bring the yarn over the hook, and draw this loop through the first one. *Insert the hook into the next stitch to the right (figure 1), draw up a loop, bring the yarn over the hook again (figure 2), and draw this loop through both loops on the hook; repeat from * until the entire edge has been covered (figure 3). Cut the yarn and secure the last loop by pulling the tail through it.

Let's say you want a vest with a finished chest measurement of 48" (122 cm). If you've made eight 12" (30.5 cm) squares, you merely need to assemble them. You can do this with your favorite sewing method or with single crochet. You'll use two squares for the right front, two for the left front, and four for the back. Follow directions for the Rhapsody

in Blues jacket shown on page 11, omitting the sleeves. If you want the same vest but have made eight 10" (25.5 cm) squares, you can simply frame the squares. Choose a color for the border and work 1" (2.5 cm) of crochet around all four sides of each motif, thus making each a 12" (30.5 cm) square. Block the finished pieces and then crochet them together.

RHAPSODY IN BLUES JACKET

You can use your stash of yarns or choose all new ones as Valentina did; she chose Tahki Yarns in many different colors, fibers, and textures, with Chelsea Silk as the unifying color, using some of it in each square and as the seaming yarn. You can make the jacket wider or longer as you wish.

The jacket shown has a 46" (117 cm) bust/chest circumference and a length of 26" (66 cm). Each square is approximately 12" (30.5 cm). The pockets are 6" × 6½" (15 × 16.5 cm), worked in single crochet and attached to the inside fronts.

YARN Tahki Yarns: Chelsea Silk (65% silk, 35% wool; 105 yd [96 m]/50 g): #189A denim, 8 balls. Cotton Classic II (100% cotton; 74 yd [68 m]/50 g): #2871 medium blue, #2609 army green, #2808 sea blue, 2 skeins each; #2939 deep lavender, 1 skein. Acapulco (46% cotton, 44% polyamide, 10% viscose; 81 yd [75 m]/50 g): #1083 turquoise, 1 ball. Siena (48% viscose, 34% wool, 18% polyamide; 100 yd [92 m]/50 g): #8012 Amazon, 2 balls. Classic Cotton Dot (100% cotton; 77 yd [71 m]/50 g): #7363 mustard, 1 ball. Lin-

guine (100% cotton; 103 yd [95 m]/50 g): #714 midnight, #719 amber, 1 skein each. Stahl Wolle Samba (62% cotton, 38% viscose; 98 yd [90 m]/50 g): #4106 kiwi, #4117 navy, 1 ball each.

NEEDLES Appropriate size for yarn choice.

NOTIONS Crochet hook to match needle size, seven 1" (2.5 cm) assorted buttons. This jacket consists of twelve 12" (30.5

cm) knitted squares, each framed with one row of single crochet. Each square is joined to the next with single crochet worked on the right side, creating a ridge. The neck, front, and bottom are finished with two rows of single crochet and edged with a row of reverse single crochet. Three-stitch gaps are left in the row of reverse single crochet for the buttonholes on the right front. The stand-up collar is one row of double crochet edged with a row of reverse single crochet.

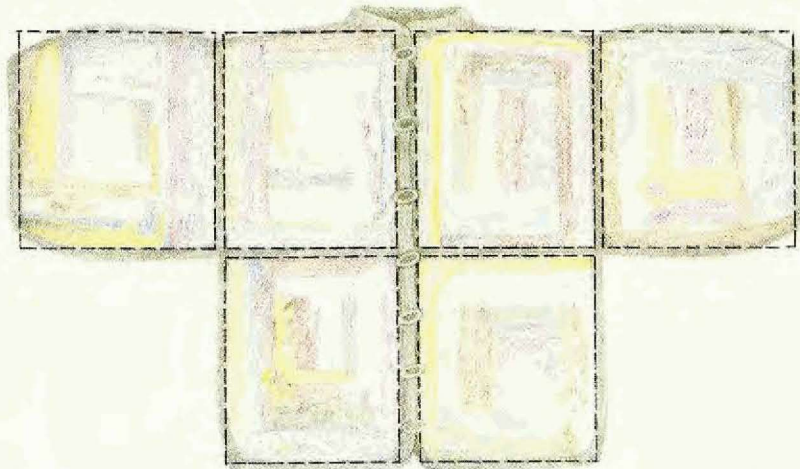

VARIATIONS

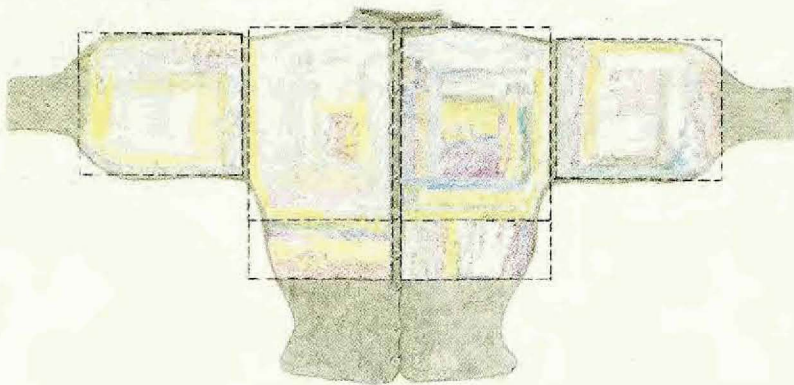

Bomber Jacket

Eight squares are outlined with single crochet, then joined with a single crochet ridge on the right side. The midriff is comprised of one rectangle knit vertically and one knit horizontally—the back mimics the front. Once the midriff rectangles are attached to the body squares with a single crochet ridge on the right side, stitches are picked up along the lower edge and a deep knit 1, purl 1 rib is knitted down to desired length. The neckband is two rows of double crochet with a final row of reverse single crochet continuing down the front and along the lower edge. The cuffs are worked downward to the wrist. (See cuff explanation under *Four-Square Jacket* on page 14.) The buttonholes are worked as chains in reverse single crochet.

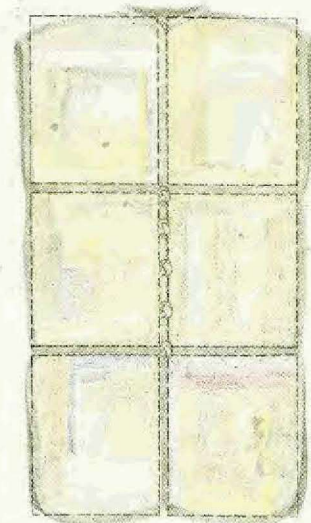

Long Vest

This vest comprises twelve squares that combine to give the desired finished measurements. The squares and seams are worked with single crochet on the right side, creating a ridge. The neck, center front, and side slits are edged with one row of single crochet followed by one row of reverse single crochet.

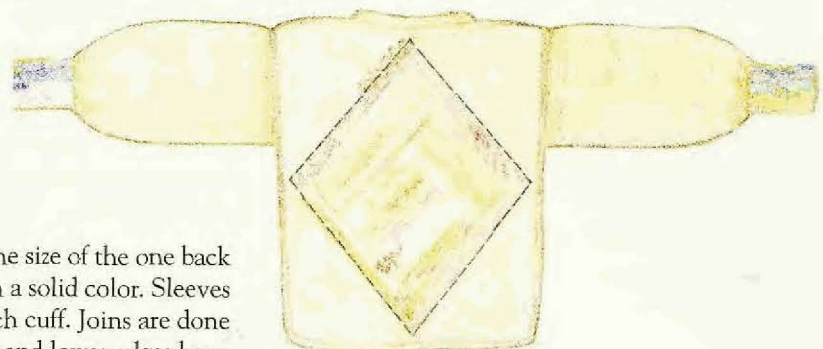

Diamond Jacket

The front is comprised of four squares that are $\frac{1}{4}$ the size of the one back square. The areas around the squares are filled in with a solid color. Sleeves are knit in garter stitch straight down to a garter-stitch cuff. Joins are done in single crochet ridge on right side, and neck, fronts, and lower edges have single crochet bands finished with reverse single crochet.

Diamond motifs begin with perfect squares; as squares are worked, they are folded into triangles and worked until the edges match; this avoids the need to measure. The same number of stitches are picked up on each side of the squares, and one stitch is decreased at the beginning of each row. The squares are decreased down to one stitch and fastened off.

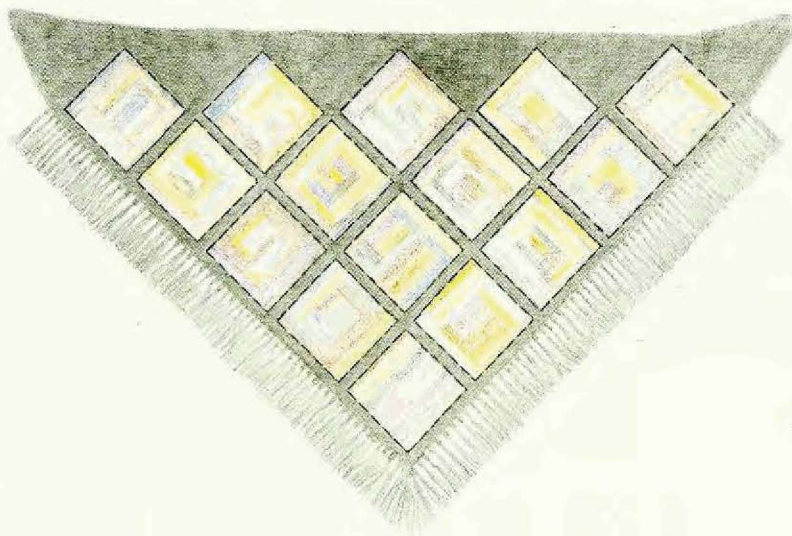

Triangular Shawl

Two rows of single crochet are worked around each square and they are joined with a single crochet ridge on the right side. The solid-colored triangles are worked separately and attached to squares with single crochet on the right side. A single crochet edging is worked on two sides as follows: single crochét into a stitch, chain two, skip one stitch and single crochet into the next stitch. This makes loops for attaching fringe.

Four-Square Jacket

The four squares are each outlined with one row of single crochet then joined to the next with a single crochet ridge on the right side. The band below the squares is worked sideways around the body and attached to the squares with single crochet on the right side. The sleeves are worked flat, attached to the body squares with single crochet on the right side, and finished with five rows of garter stitch. The neck, front, and lower edges are worked with one row single crochet and then one row reverse single crochet. The cuffs are worked by picking up all the stitches at the bottom of the sleeve square and decreasing down to the number of stitches necessary for the wrist, forming a gathered sleeve. For example, pick up 100 stitches and work one row, decreasing 60 stitches evenly spaced to 40 stitches. Work the 40 stitches for desired cuff length. The buttonholes are crochet chains.

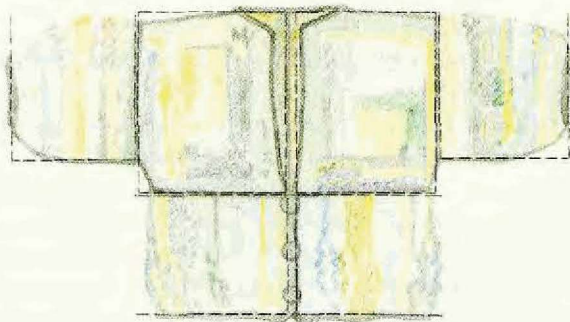

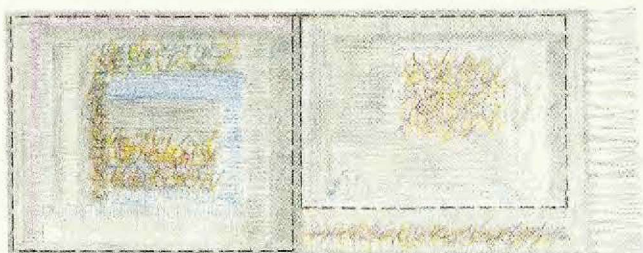

Squares Scarf

Squares are joined with single crochet on the right side, and a fringed edging is worked as for *Triangular Shawl*, page 14.

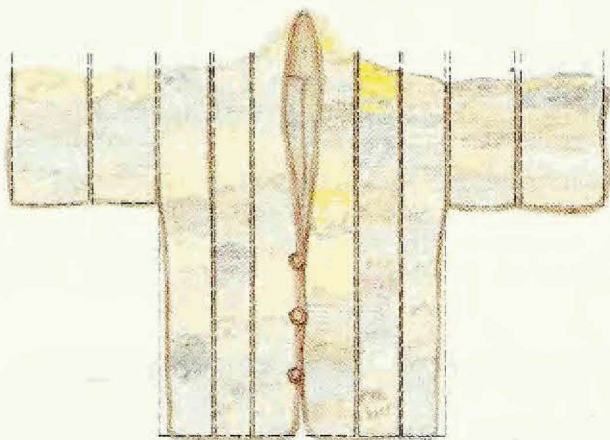

Mindless Knitting Jacket

Another variation on the creative knitting theme is what Valentina terms "mindless knitting". This involves knitting strips in irregular fashion. Cast on about two to three inches of stitches and work randomly, changing knits and purls whenever you feel like it. Change yarn as you like, and work the strip to the length needed for your garment; the strips go up from the front bottom edge, over the shoulder, and back down to the back bottom edge. Work as many strips as you need to equal the width of the body. The sleeves are also worked in strips.

When working mindless knitting, keep the last two to three edge stitches in garter stitch. If the edges become wavy, you can fill these areas in with crochet as you put the strips together. For finishing, each strip is edged in single crochet and then crocheted together with a solid border color in single crochet on the right side. Edgings are one row single crochet, then one row reverse single crochet.

You can use creative knitting modules to make garments, pillows, afghans, wall hangings, and probably other things we haven't thought of. Be creative and have fun. 

GGH Rebecca
Collection



NEW for 1998
SPRING/SUMMER
Knitting Magazine

*Includes 21
Wonderful
New Patterns!*

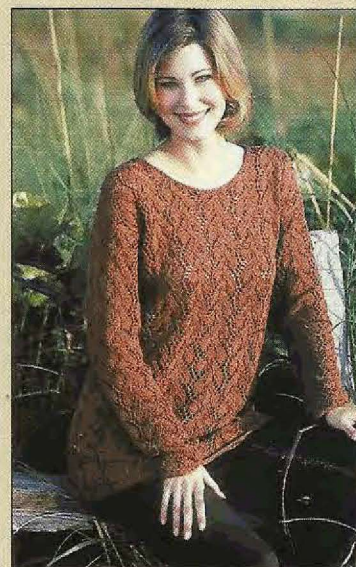

Available at fine yarn shops,
or send \$11.95 USD to:
Muench Yarns dept GGH103
118 Ricardo Rd.
Mill Valley, CA 94941-2461

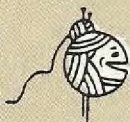

MUENCH YARNS

The KNITTING TREASURES of SCANDINAVIA!

INTERWEAVE PRESS
SCANDINAVIAN JOURNEY
JUNE 15-29, 1998

This June, two glorious weeks in Sweden, Norway, and Denmark will bring you

The leadership of Marilyn Murphy, editor of *Interweave Knits*, and Nancy Bush, author of *Folk Socks*. While in Sweden, Nancy will conduct a two-day Nordic Knitting Workshop for tour members

- Meetings with Scandinavian knitwear designers in their studios
- Private showings of important historical and regional garments
- A special visit to the Dale of Norway mill and knitwear facility.

Plus beautiful Scandinavian scenery, guided tours, shopping adventures, and the fun and excitement of Sweden's Midsummer Eve celebrations. There's also an optional two-day Domino Knitting Workshop with Vivian Høxbro in Copenhagen.

For details of *Knitting in Scandinavia*, send a business-size SASE to
INTERWEAVE PRESS
SCANDINAVIAN JOURNEY
201 East Fourth Street
Loveland, CO 80537-5655

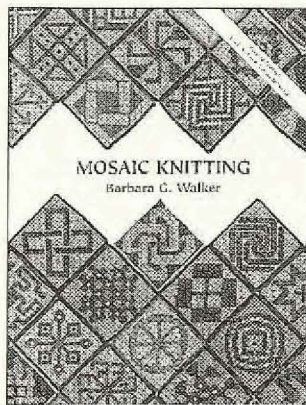

Barbara G. Walker

-Mosaic Knitting
A Treasury of Slip-Stitch Patterns including 116 new never-before-published "Magic Mosaics". Hc \$31

-Knitting From the Top
Everything from the top: sweaters of all styles, pants, capes, hats, skirts, etc. pb \$20

-Learn-to-Knit Afghan Book

Excellent for Beginners as well as

experienced knitters. pb \$20. (Afghan Kit available at special price)
Postage: \$4 for 1st book + \$1 each add'l.

Add \$5 for a full catalog plus wool samples (13 kinds) including all 156 Shetland colors by #

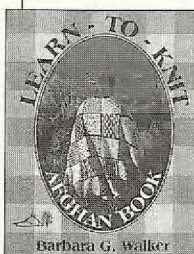

Schoolhouse Press, Pittsville, WI 54466

Order (in the US): 800-YOU-KNIT (968-5648)

Questions: 715-884-2799 Since 1959

Fax: 715-884-2829



Especially for Ewe!

Order the Kits and Yarns
in this issue -

1-800-933-9665

FEATURED BOOKS

- The Jean Moss Book of World Knits by Jean Moss
- Mosaic Knitting by Barbara Walker
- Colorful Knits for You and Your Children by Zoe Mellor
- Traditional Lace Knitting by Furze Hewitt
- Pacific Coast Highway by Alice Starmore
- Bears and Rabbits to Knit by Bear Brain Creations
- Not Just Plain Jane Knits by Jane Elliott
- Custom Fit Socks and Mittens by The Fiber Gypsy
- Pine Tree Yarns, Handpainted Yarns by Elaine Davey
- Icelandic Lacewight Wool, School House Press

THE WOOL CONNECTION

34 East Main Street,
Old Avon Village North, Avon, CT 06001



1-860-678-1710 • Fax 860-677-7039

http://www.woolconnection.com E-mail: wool@tiac.net

Irene Krieger * Morgan Hicks * Manon Salois * Susanna Lewis * Diane Bennett * Susan Gaughini * Terri Burns * Cheryl Jiles

The Midwest's Largest Knitting Event of 1998



MKS Forum
for BOTH Machine and Hand Knitters



- * 13 classes
- * 65 teachers
- * 3 Fashion Shows
- * Marketplace with over 55 vendors
- * 3 Luncheons

Sept 3-6, 1998
Dallas, Texas

\$195 Price is complete package if mailed by 6/1/98. Single day prices also available

For a registration booklet call 1-800-628-8047

Sponsored by Fiber Circle Publishing
Machine Knitters Source Magazine

Leslie Solomon * Kathleen Powers-Johnson * Mary Engelson * Karen Kuranda * John Allen * Susan Lazzari

Lily Chin * Ginger Lutens * Evie Rosen * Nancie Wiseman

The World's Largest Selection of Knitting Supplies

Where to Get the Yarn

THE BUTTONS, THE BOOKS & THE TOOLS

Yarn Packs for this issue

- **Blanket Stitch Pillows**
- **Garter Stitch Gymnastics Vest**
- **Parfait Sundress**
- **Tartan Pullover**
- **Creative Knitting Jacket**

Your source for all books reviewed in this issue



Let us put Yarn Paradise in your mailbox! Ask for our 84 page full color catalog and newsletter subscription.

Visit us in person at our Yarn Warehouse or on the web at <http://www.patternworks.com>

Introducing The Sweater Wizard



Create a sweater pattern in a minute with the latest software for knitters. Circular and flat styles with desired ease. Customize sweater diagram on screen. *Windows 3.1/3.11 or 95/NT.*
D-106 The Sweater Wizard \$89.95



Stitch & Motif Maker

The first paint program especially for knitters! Creates a grid up to 40 sts by 60 rows. 74-color and user-friendly symbol palettes. *Windows 3.1/3.11 or 95/NT.*
D-107 Stitch & Motif maker \$89.95
D-10P67 Both Programs \$159

patternworks

Where your satisfaction is absolutely guaranteed

Orderline: 1-800-438-5464

PO Box 1690, Dept IKSP98, Poughkeepsie, NY 12601

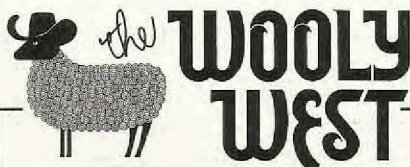

Fine natural fiber yarns and accessories for handknitters

We specialize in small projects!

Everything from yarns and patterns to books and needles.

Mailorder Catalog
Send or call for our free catalog.

1417 South 1100 East
Salt Lake City, UT 84105
(801) 487-9378

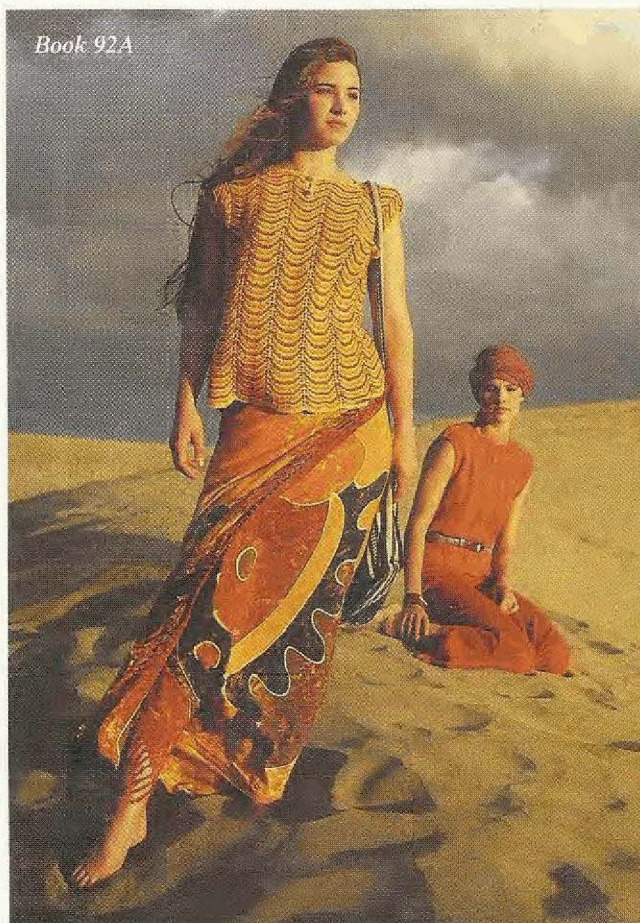

Book 92A

*Kolibri...
luxurious Egyptian cotton in a wide array of brilliant colors.*

*Call for your nearest shop & our free brochure
800-441-DALE*



DALE OF NORWAY, INC.
Quality from Nature Since 1879

N16 W23390
Stoneridge Drive, Suite A
Waukesha, WI 53188



GARTER-STITCH GYMNASTICS VEST

ANNE MORGAN JEFFERSON

Garter-stitch blocks

Handpainted yarn

FINISHED SIZE 36 (40, 44, 48, 52)" (91.5 [101.5, 112, 122, 132] cm) bust/chest circumference. Vest shown measures 40" (101.5 cm).

YARN Schaefer Helene (50% silk, 50% wool; 875 yd/14 oz [800 m/397 g]): icy pastels, 2 skeins.

NEEDLES Body—Size 8 (5 mm): straight and 24" (60 cm) circular (cir). I-Cord—Size 8 (5 mm): double-pointed (dpn). Adjust needle size if necessary to obtain the correct gauge.

NOTIONS Tapestry needle.

GAUGE 18 sts and 36 rows = 4" (10 cm) in Garter st.

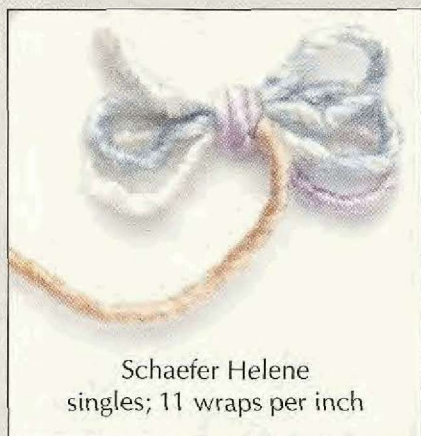

Schaefer Helene
singles; 11 wraps per inch

THIS LONG VEST is knitted in what I call garter-stitch gymnastics—blocks of garter stitch worked at right angles to each other. Because each stitch is the same width as a ridge (two rows) is tall, garter stitch works easily into square shapes. By picking up one stitch for each ridge along the side of a garter-stitch piece, another block or section can be worked at right angles to the first and the resulting fabric will lie flat. The different knitting directions are emphasized by the garter-stitch ridges and color changes in the handpainted yarn. This technique brings refreshing sophistication to simple garter stitch. The edges are finished with attached I-cord (see Glossary, page 6). Adjustments for a shorter version are provided.

Don't be alarmed if your knitting looks too wide. The nature of garter stitch and the luxurious quality of the silk/wool yarn will cause the garment to stretch in length, narrowing the basic squares to rectangles. This fact has been accounted for in the finished measurements. The vest is best worn with about four inches (ten cm) of ease.

•**Back:** Work through Section 3 of the

Basic Square until 1 st rem on final BO row. This completes Square 1. *Turn piece 90° and with RS facing, pick up and knit 1 st for each ridge or st—30 sts; 10 sts in each section. Work through Section 3 of the Basic Square until 1 st rem on final BO row. Rep from * twice more—4 squares have been completed (see diagram on page 20). BO all sts and cut yarn, leaving a tail long enough to seam the side of Square 4 to CO edge of Square 1. Foll diagram, join yarn and with RS facing, pick up and knit 30 sts along side of Square 1 and work Square 5. Work Square 6 along upper edge of Square 5 (as for Square 2). Then work Square 7 along side of Square 6 (as for Square 2). BO all sts and cut yarn, leaving a tail long enough to seam the side of Square 7 to BO edge of Square 1. Join yarn and work Square 8 along top of Square 2. BO all sts and cut yarn, leaving a tail long enough to seam the side of Square 8 to BO edge of Square 7. Join yarn and work Square 9 along side of Square 5 as shown and seam the side of Square 9 to the BO edge of Square 4. Join yarn and work Square 10 on the rem edge of Square 7, and then rep Section 2 of Basic Square to

Basic Square

Section 1: Using the cable method (see page 21), cast on 30 sts.

Rows 1–19: Knit.

Section 2: Using the backward loop method (see page 21), cast on 10 sts at the end of Row 19 of Section 1.

Row 1: (RS) K9, k2tog (the rem st of the 10 sts just CO with the first st of the original 30), turn.

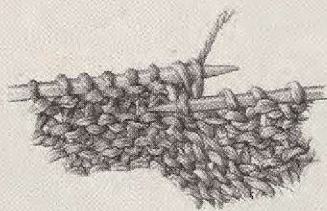

Row 2: Knit.

Rep these 2 rows until all sts are joined, ending with Row 1. BO 9 sts—1 st rem on needle.

Section 3: Turn piece 90°, and with WS facing, pick up and purl 1 st in each rem ridge along side of Section 2 and 1 st in the corner—31 sts.

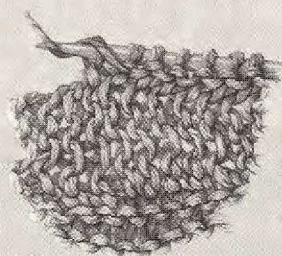

Row 1: (RS) P2tog, purl to end—30 sts.

Rows 2–18: Purl.

Row 19: BO all sts in purl—10 ridges.

To join a new section of garter st to a finished edge of knitting, knit the last st of the new section tog with the nearest BO st or ridge of the existing section.

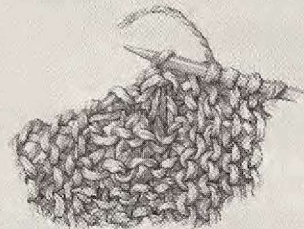

Take care to maintain a ratio of 1 ridge (2 rows) of knitting for every pre-existing st or ridge.



make an elongated Square 10. BO all sts. **Left shoulder and side:** With cir needle and RS facing, pick up and knit 40 sts (1 st for each BO st or ridge) along side of Square 10.

Row 1: (WS) Knit.

Row 2: Knit to last st, knit this st tog with closest BO st of Square 8.

Rep these 2 rows until there are 18 ridges on RS of work. On next row (WS), k8, BO rem 32 sts—19 ridges on RS. Rejoin yarn and beg with RS facing, work rem 8 sts as follows:

Row 1: (RS) Knit to last st, knit last st tog with nearest BO st of Square 8.

Row 2: Knit to last 2 sts, k2tog.

Rep these 2 rows until 4 sts rem. Work even on 4 sts, working last st of each RS row tog with nearest BO st until a total of 30 ridges have been worked. On the next row (RS), k4, pick up and knit 1 st for every ridge or BO st along the side of Square 8, Square 2, and then Square 3—94 sts. Knit even for 0 (9, 19, 29, 39) rows. BO all sts on next WS row—1 (5, 10, 15, 20) ridges on RS of work. **Right shoulder and side:** Work as for left shoulder and side, reversing all shaping and working last live st of each WS row tog with nearest BO st of Square 6 until 30 ridges have been worked, ending with a WS row. Cut yarn. Rejoin yarn at lower right corner of Square 9 and pick up and knit a total of 90 sts along side of Square 9, Square 5, and Square 6, and then knit 4 live armhole sts—94 sts. Cont as for left side.

•**Left Front:** (Worked from the top down.) Using the cable method, CO 19 sts. *Knit 19 rows. Using backward loops, CO 10 sts and work as for Section 2 of Basic Square. BO all sts at end of last row. Rejoin yarn and pick up and knit 1 st for each ridge along side of section just completed. Rep from * but do not BO after all sts have been joined. **Shape armhole:**

Row 1: (RS) Knit to last 2 sts, k2tog.

Row 2: Knit.

Rep these 2 rows until 4 sts rem. Work even on 4 sts until 29 ridges have been worked. BO all sts on next WS row—30 ridges on RS. Cont as for Sections 1 and 2 of Basic Square until a total of 7 horizontal sections and 6 vertical sections have been worked. BO all sts. With cir needle, RS facing, and beg at lower right corner, rejoin yarn and pick up and knit 94 sts evenly spaced along right side edge of piece

just completed. Knit even for 0 (9, 19, 29, 39) rows. BO all sts on next WS row—1 (5, 10, 15, 20) ridges on RS. **Center band:** With cir needle, RS facing, and beg at upper left corner, pick up and knit 130 sts evenly spaced (10 sts for each section) along left edge of piece.

Rows 1–4: Knit. Then begin short-row shaping as follows:

Row 5: (WS) K100, turn.

Rows 6 and 8: YO, knit to end.

Row 7: K95, turn.

Rows 9–24: Rep last 2 rows, working 5 fewer sts each WS row (55 sts worked on Row 23).

Row 25: Knit, working each yo tog with the st after it (i.e., k2tog)—130 sts.

Rows 26 and 27: Knit.

BO all sts.

•**Right Front:** Work as for left front until 3 sections have been completed (2 horizontal sections and 1 vertical). Do not BO. Set aside. **Armhole section:** With new yarn and using the cable method, CO 4 sts. Rows 1–9: Knit—5 ridges on RS of work. Row 10: Knit, inc in last st—5 sts. Row 11: Knit.

Rep last 2 rows until there are 10 sts, ending with a WS row. On the next row, k9 and then with RS facing, knit last st tog with first live st of front, turn. Cont as before, working last st tog with nearest live st of front every RS row until no live sts rem. BO rem 10 sts. Cont working Sections 1 and 2 of Basic Square until a total of 7 horizontal and 6 vertical sections have been worked. BO all sts. With cir needle, RS facing, and beg at armhole, rejoin yarn and pick up and knit 94 sts evenly spaced along left side edge of piece just completed. Knit even for 0 (9, 19, 29, 39) rows. BO all sts on next WS row—1 (5, 10, 15, 20) ridges on RS. **Center band:** With cir needle, RS facing, and beg at lower right corner, pick up and knit 130 sts evenly spaced (10 sts for each section) along right edge of piece.

Rows 1–3: Knit.

Row 4: (RS) K100, turn.

Rows 5 and 7: YO, knit to end.

Row 6: K95, turn.

Rows 8–23: Rep last 2 rows, working 5 fewer sts each WS row (55 sts worked on Row 23).

Row 24: Knit, working each yo tog with the st after it (i.e., k2tog)—130 sts.

Rows 25 and 26: Knit.

BO all sts.

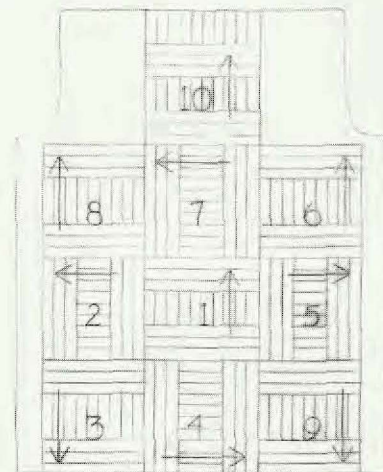

Long version. Work the squares in the order and directions shown (see page 18).

•**Finishing:** With yarn threaded on a tapestry needle, sew shoulder seams, matching each st to a ridge. Sew side seams from armhole edge to 3 sections from lower edge, matching stitch for stitch. **Lower back edging:** Work 3-st attached I-cord (see Glossary, page 6) across lower back. **Armhole edging:** Beg at side seam, work 3-st attached I-cord around armhole. **Front edging:** Beg at lower right front side-seam opening, work 3-st attached I-cord across lower right front edge, up right front opening, across back neck opening, down left front opening, and across lower left front edge, working 2 rows of unattached I-cord at each corner. Weave in loose ends, following grain of garter st when possible.

SHORT VERSION

•**Back:** Work Square 1 through Square 5 as for long version above. BO all sts at end of Square 5. Join yarn and work Square 6 along right side edge of Square 5. BO all sts. Seam side of Square 6 to BO edge of Square 4. Join yarn and work Square 7 along rem edge of Square 4. Complete as for Square 10 of long version. Work armhole shapings as for long version. Work sides with a total of 64 sts along each side edge.

•**Fronts:** Work as for long version, working just 10 sections in length instead of 13. Work sides on a total of 64 sts each. Work center bands on 100 sts, beg short-row shap-

ing by working to within 30 sts of shoulder and working 5 fewer sts every other row until 25 sts have been worked for last short row. Finish as for long version. 

Anne Morgan Jefferson of Hampton Falls, New Hampshire, has been knitting since early childhood and has been editing, designing, and teaching knitting on a national basis for the past twenty years. Knitting is so much a part of her life, she has ventured out of the house more than once wearing a forgotten circular needle around her neck. Occupational jewelry, she calls it.

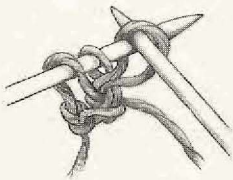
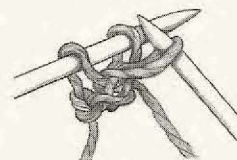
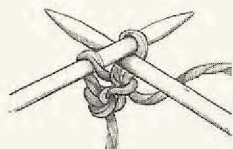

Cable Cast-On. Cast on two stitches using the knitted cast-on method. Insert the right needle between the two stitches on the left needle. Wrap the yarn as if to knit. Draw the yarn through to complete the stitch, but do not drop the stitch from the left needle. Slip the new stitch to the left needle as shown. Continue in this fashion, working between the last two stitches on the needle, until you have the desired number of stitches.



Backward Loop Cast-On. Make a loop in the yarn and place it on the needle backward so that it doesn't unwind. Continue for required number of stitches, adjusting tension.

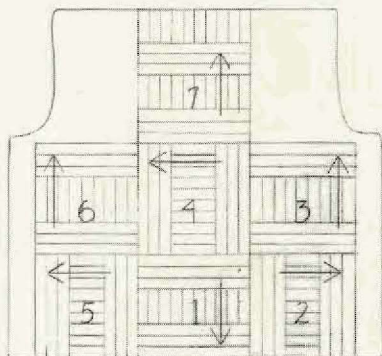

Short version. Work the squares in the order and directions shown.

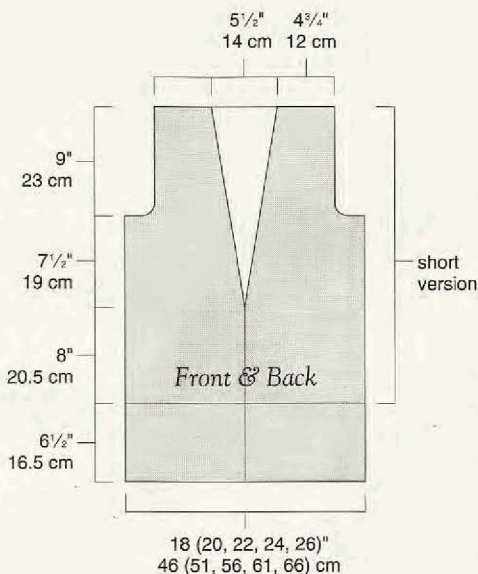

Schaefer Yarns

For Pattern #70 and samples send \$2.50 US to:
Schaefer Yarns
Kelly's Corners
Interlaken, NY
14847

EXTRAORDINARY HAND PAINTED FIBERS

CALL 1 ~ 800 FOR YARN (867 ~ 9276) for the dealer nearest you.



DOMINO SHELLS

Step-by-Step

Vivian Høxbro

DOMINO SHELLS offer an innovative knitting technique that allows easy designing because the shells can be built on one another as you choose, both horizontally and vertically. You work each three-color shell upward from a wide base to a narrow top in a combination of garter stitch, slip stitch, and ribbing. You work the contrast-color rows with larger needles so that these stitches stand out against the main-color background.

You can make the shells larger or smaller by using more or fewer stitches or by using thicker or thinner yarn and/or larger or smaller needles.

This technique is ideal for combining many colors and textures of yarn.

TECHNIQUES

Knitted Cast-On (K-CO):

Step 1: Make a slip knot and place it on a needle held in your left hand.

Step 2: With a free needle, knit into the slip knot (figure 1) and place the new st twisted onto the left needle (figure 2)—2 sts on left needle.

Rep Step 2, always knitting into the last st made (not the slip knot).

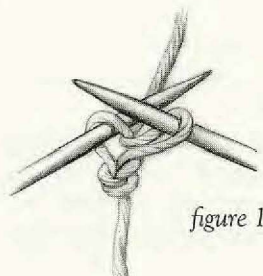

figure 1

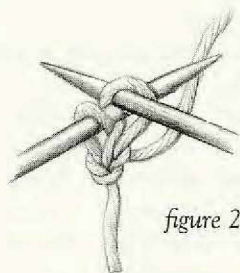

figure 2

Darning while Knitting: If you use the Continental style of knitting (holding the yarn in your left hand), darn in the tail ends of yarn as you go as follows: Knit with the “new” color, N, wrapped around both your index finger and middle finger and the “old” color, O, wrapped only around your index finger (at the inner side of N). Slip the selvedge st kwise.

Step 1: K1 by putting the needle under O and knitting with N (figure 3).

Step 2: Knit the next st by putting the needle over O and knitting N (figure 4).

Rep these steps 5 to 6 times.

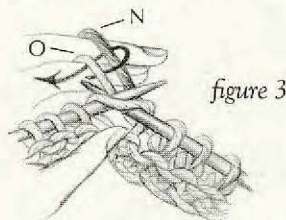

figure 3

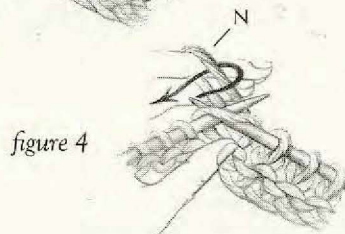

figure 4

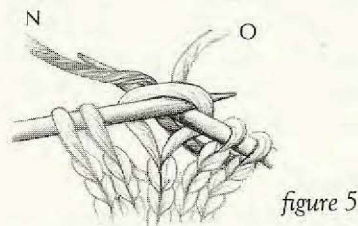

figure 5

If you follow the English style of knitting (holding the yarn in your right hand), use the following method: *Place O over the top of the right needle from back to front. N then goes over the right needle and O is passed over N to the right of the needle. Knit the st with N, drawing the new loop to the front beneath O (figure 5). When you do this, be sure that O is above the N st, is caught in, and does not show on the right side. K1 with N; rep from * 5 to 6 times.

Note: Yarn ends at the left-hand side of the work cannot be darned this way; they will have to be woven in with a tapestry needle.

Trimming Yarn Ends: When the yarn ends have been darned, cut them, leaving a $\frac{3}{8}$ " (1 cm) tail to prevent the ends from shifting to the right side of the garment.

PRACTICE PIECE

To learn the domino technique, knit the following series of eight domino shells as illustrated, beginning with Basic Shell 1. The shells are numbered in the order they are to be worked. These eight shells are used in the top and jacket shown on page 22. The neck and shoulder shapings are worked with simple variations of these shells.

To get familiar with the technique, work the first shell without darning in the ends. Then darn in the ends of the remaining shells as you work them; it is really quite easy to do and will save you considerable time in finishing.

1. Basic Shell 1

With larger needles and color 3, K-CO 29 (33) sts (figure 1).

figure 1

Row 1: (WS) With color 3, knit.

Row 2: (RS) Change to smaller needles and color 1. Knit.

Row 3: Knit.

Row 4: Change to larger needles and color 2. *K1, sl 1 wyb; rep from *, end k1.

Row 5: *K1, sl 1 wyf; rep from *, end k1.

Rows 6 and 7: Change to smaller needles and color 1. Knit.

Rows 8 and 9: With color 3, rep Rows 4 and 5.

Row 10: Change to smaller needles and color 1. Knit.

Row 11: K2tog to last st, k1—15 (17) sts rem.

Rows 12 and 13: With color 2, rep Rows 4 and 5.

Row 14: Change to smaller needles and color 1. Knit.

Row 15: For small size only: *K1, k2tog, k2, k2tog; rep from *, end k1—11 sts rem. For large size only: *K2tog, k1; rep from *, end last rep k2tog—11 sts rem.

Row 16: Knit.

Row 17: K1, *p1, k1; rep from *.

Rows 18–21: Cont in established ribbing.

For small size only:

Rows 22, 24, 26, and 28: SSK, cont in established ribbing to last st, k1—1 st dec'd.

Rows 23, 25, 27, and 29: P2tog, cont in established ribbing to last st, p1—1 st dec'd.

Row 30: (RS) Sl 1, p2tog, psso.

For large size only:

Rows 22 and 23: Cont in established ribbing.

Rows 24, 26, 28, and 30: SSK, cont in established ribbing to last st, k1—1 st dec'd.

Rows 25, 27, 29, and 31: P2tog, cont in established ribbing to last st, p1—1 st dec'd.

Row 32: (RS) Sl 1, p2tog, psso.

Cut yarn and pull tail through rem st.

2. Basic Shell 2



figure 2

With larger needles and color 3, K-CO 14 (16) sts, turn, and pick up and knit 1 st at the lower right corner of shell 1 (with RS facing) and 14 (16) sts evenly spaced up right edge of the same shell—29 (33) sts (figure 2). Work as for Basic Shell 1.

3. Basic Shell 3

With larger needles and color 3, pick up and knit 14 (16) sts down left edge of shell 1, 1 st at lower left corner of the same shell, and with WS facing, K-CO 14 (16) sts—29 (33) sts (figure 3). Work as for Basic Shell 1.

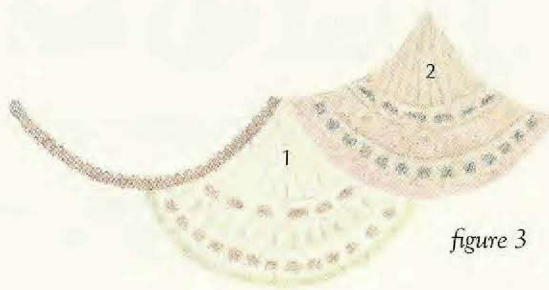

figure 3

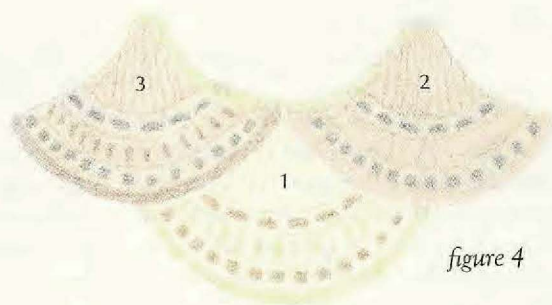

figure 4



figure 5

4. Basic Shell 4

With larger needles, RS facing, and color 3, pick up and knit 14 (16) sts down left edge of shell 2, 1 st at top of shell 1, and 14 (16) sts up right edge of shell 3—29 (33) sts (figure 4). Work as for Basic Shell 1.

5. Half Shell 1

With larger needles and RS facing, pick up and knit 14 (16) sts down left edge of shell 3 and 1 st at lower left corner of the same shell—15 (17) sts (figure 5). Work Rows 1–10 of Basic Shell 1.

Row 11: (WS) With color 1, k2tog to last st, k1—8 (9) sts rem.

Row 12: Change to larger needles and color 2. KO (1) *k1, sl 1; rep from *, end k2.

Row 13: K1, *k1, sl 1; rep from *, end k1 (2).

Row 14: Change to smaller needles and color 1. Knit.

Row 15: For small size only: K1, k2tog, k2, k2tog, k1—6 sts rem. For large size only: K1, k2tog, k1, [k2tog] twice, k1—6 sts rem.

Row 16: Knit.

Row 17: P1, [k1, p1] twice, p1.

Rows 18–21: Cont in established ribbing.

For small size only:

Rows 22–28: Cont in established ribbing, beg every RS row sl 1 kwise, k1, psso. Beg and end every WS row with p1—2 sts rem. Cut yarn and pull tail through rem st.

For large size only:

Rows 22 and 23: Cont in established ribbing.

Rows 24–31: Cont in ribbing, beg every RS row sl 1 kwise, k1, psso, and end every RS row k1. Beg and end every WS row with p1—2 sts rem.

Row 32 (WS) P2tog. Cut yarn and pull tail through rem st.



figure 6

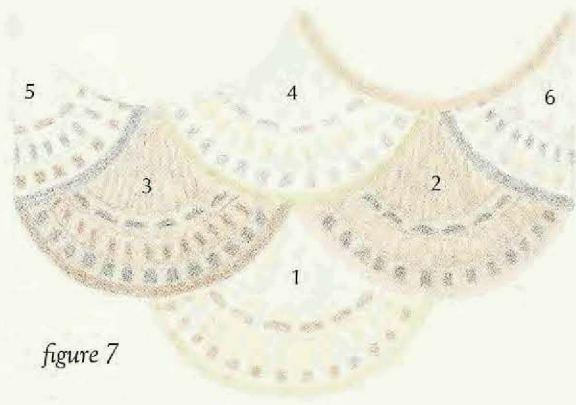

figure 7

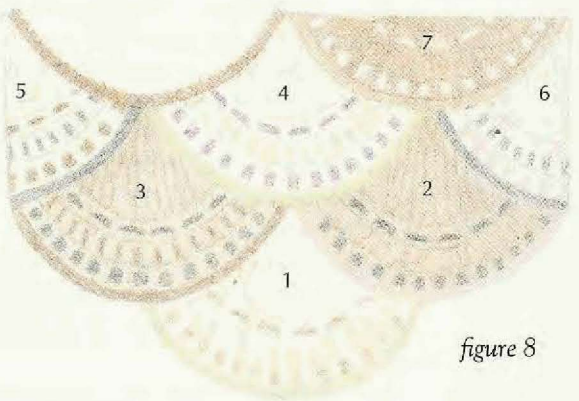

figure 8

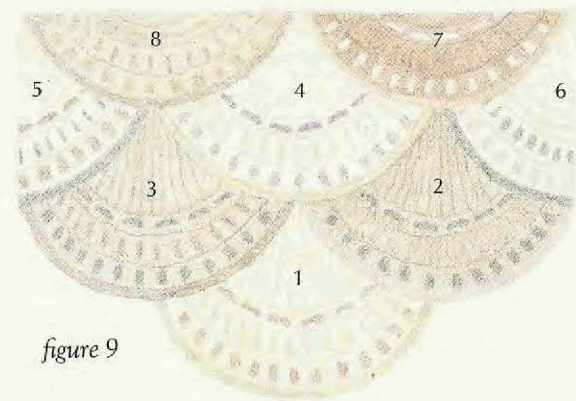

figure 9

6. Half Shell 2

With larger needles and RS facing, pick up and knit 1 st at lower right corner of shell 2 and 14 (16) sts up right edge of the same shell—15 (17) sts (figure 6). Work as for Half Shell 1 through Row 21 (23)—6 sts.

For small size only:

Rows 22–28: Cont in established ribbing, beg every RS row with k1 and end with k2tog. Beg and end every WS row with p1—2 sts rem.

Row 29: (WS) P2tog. Cut yarn and pull tail through rem st.

For large size only:

Rows 24–31: Cont in established ribbing, beg every RS row with k1 and end with k2tog. Beg and end every WS row with p1—2 sts rem.

Row 32: (WS) P2tog. Cut yarn and pull tail through rem st.

7. Half Circle

With larger needles and RS facing, pick

up and knit 14 (16) sts down left edge of shell 6, 1 st at top of shell 2, and 14 (16) sts up right edge of shell 4—29 (33) sts (figure 7). Work Rows 1–16 of Basic Shell—11 sts rem.

Row 17: (WS) *K2tog to last st, k1; rep from *—6 sts rem.

BO all sts.

8. Half Circle

With larger needles and RS facing, pick up and knit 14 (16) sts down left edge of shell 4, 1 st at top of shell 3, and 14 (16) sts up right edge of shell 5—29 (33) sts (figure 8). Work Rows 1–16 of Basic Shell—11 sts rem.

Row 17: (WS) *K2tog to last st, k1; rep from *—6 sts rem.

BO all sts.

This completes the eight shells of the practice piece (figure 9). Shell 4 is surrounded on all sides by other shells and can be used to measure your gauge. ☞

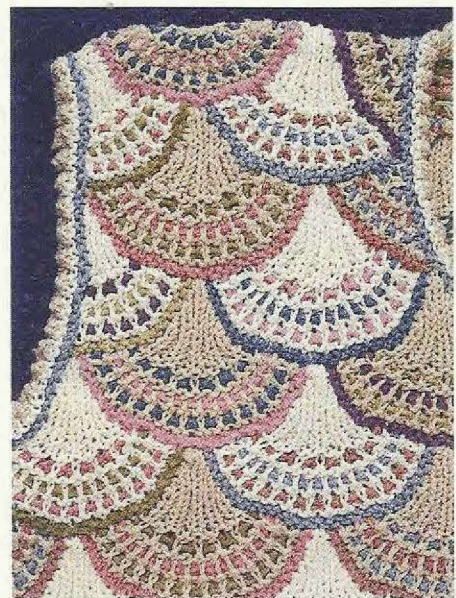

Vivian Høxbro has been professionally designing knitwear for more than ten years. She lives in Copenhagen, Denmark.



DOMINO SHELLS TOP AND JACKET

VIVIAN HØXBRO

Color and texture • Worked one shell at a time

FINISHED SIZE *Top:* 39½ (43½)" (100 [110] cm) bust/chest circumference. Top shown measures 43½" (110 cm). *Jacket:* 40 (44)" (102 [112] cm) bust/chest circumference. Jacket shown measures 44" (112 cm).

Note: You can make each garment larger or smaller by working more or fewer shells, knitting larger or smaller shells, using thicker or thinner yarn, or using larger or smaller needles.

YARN *Top:* Rowan Cotton Glacé (100% cotton; 125 yd [115 m]/50 g): #730 oyster, #725 ecru, 4 (5) balls each; #788 hazel, #440 lilac wine, #748 mint, #780 pear, #744 Provence, #783 shrimp, 1 (1) ball each. Rowan Fine Cotton Chenille (85% cotton, 15% polyester; 173 yd [158 m]/50 g): #405 milkshake, #411 catkin, 1 (1) ball each. *Jacket:* Rowan Cotton Glacé (100% cotton; 125 yd [115 m]/50 g): #730 oyster, 10 (11) balls; #725 ecru, 9 (10) balls; #788 hazel, #440 lilac wine, #748 mint, #780 pear, #744 Provence, #783 shrimp, 2 (2) balls each. Rowan Fine Cotton Chenille (85% cotton, 15% polyester; 173 yd [158 m]/50 g): #405 milkshake, #411 catkin, 2 (2) balls each.

NEEDLES Size 3 and 6 (3 and 4 mm); straight. Size 3 (3 mm): 16" and 47" (40 and 120 cm) circular (cir). Adjust needle sizes if necessary to obtain the correct gauge.

NOTIONS Size C/2 (2.75 mm) crochet hook (to help pick up sts); tapestry needle; seven ⅝" (1.5 cm) buttons for jacket.

GAUGE When knitted together on all sides, each shell should measure 4 (4¼)" (10 [11] cm) across and 2¾ (3)" (7 [7.5] cm) long.



Rowan Cotton Glacé
6-ply; 16 wraps per inch

THIS TOP AND JACKET combo is worked in soft pastels representing the water, sand, seashells, and flowers near a beach. Both garments are constructed with domino shells from the lower edges to the shoulders. The side seams are done by sewing the edge shells of the back to the gaps between the edge shells of the front. If you wish, you can avoid side seams by working the front and back together in one piece (i.e., circularly) from the sixth through the eleventh row of shells. Likewise, you can eliminate sleeve seams by working the sleeves circularly.

The garments are worked according to the colored charts on page 27. The colors indicate which shape of shell to work; the numbers indicate the sequence in which to work the shells; the letters indicate the color sequence to use. For example, shell 1 on the Top Back chart is the first shell to be worked and it is to be worked as Basic Shell 1 (see page 23) in color combination B.

To ensure good fit, use a sweatshirt or sweater that fits you as your personal pattern. Then work the necessary number of shells horizontally and vertically to match that shape.

Note: Before beginning a garment, practice domino shells by working the practice piece described on the previous pages in your chosen yarns. Use this practice piece to measure your gauge.

TOP

•**Back:** Worked from the base of the center back to the neck in the sequence, shapes, and color combinations shown on the Top Back chart (see page 27). Work 1 as Basic Shell 1 of practice piece; 2, 6, 7, 15, 16, 26, and 36 as Basic Shell 2; 3, 4, 10, 11, 21, 31, and 41 as Basic Shell 3; 50 and 59 as Half Shell 1; 54 and 63 as Half Shell 2; 64–67 as Half Circle; and all other shells as Basic Shell 4.

•**Front:** Work as for the back through shell 51.

Shell 52: With larger needles and RS facing, pick up and knit 1 st at top of 48, and 14 (16) sts up right edge of 51–15 (17) sts. Work as for Half Circle, but beg on Row 3, k2tog at the beg of every RS row 4 times. End Row 11 with 6 sts and end Row 15 with 3 sts. Next row: Sl 1, k2tog, pssso.

Shell 53: Work as for Basic Shell 4.

Shell 54: Work as for Half Shell 1



Top Back

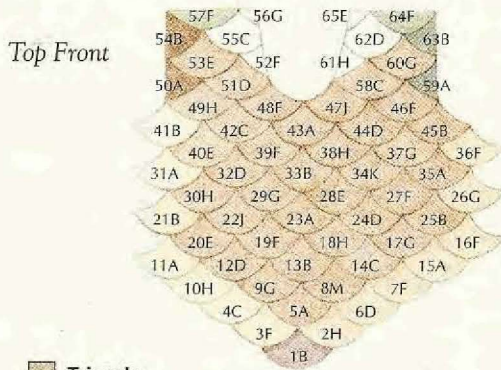

Top Front

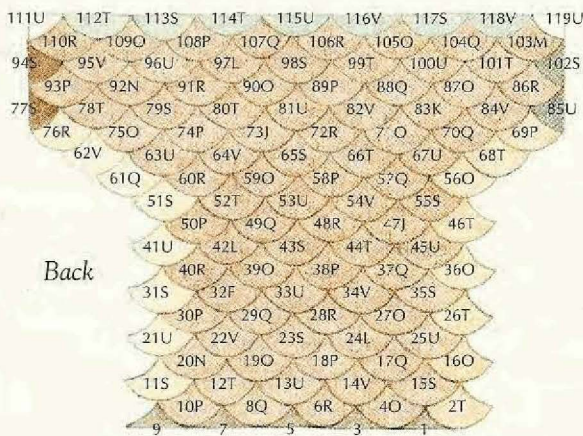

Back

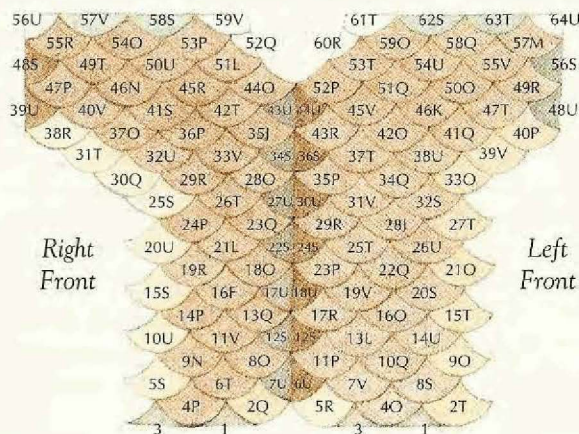

Right Front

Left Front

COLOR COMBINATION	COLOR 1	COLOR 2	COLOR 3
A	oyster	lilac wine	pear
B	oyster	shrimp	catkin
C	oyster	hazel	mint
D	oyster	milkshake	provence
E	ecru	catkin	shrimp
F	ecru	mint	hazel
G	ecru	pear	lilac wine
H	ecru	provence	milkshake
J	pear	oyster	ecru
K	hazel	ecru	oyster
L	shrimp	ecru	oyster
M	shrimp	oyster	ecru
N	hazel	oyster	ecru
O	ecru	lilac wine	pear
P	ecru	shrimp	catkin
Q	ecru	hazel	mint
R	ecru	milkshake	provence
S	oyster	catkin	shrimp
T	oyster	mint	hazel
U	oyster	pear	lilac wine
V	oyster	provence	milkshake

Shell 55: With larger needles, pick up and knit 10 (12) sts down left edge of 52, 1 st at top of 51, and 14 (16) sts up right edge of 53—25 (29) sts. Work as for Basic Shell 4, but k2tog at the beg of every RS row, and end Row 11 with 15 (17) sts.

Shell 56: Work as for 52, picking up 1 st at top of 52.

Shell 57: Work as for Half Circle.

Shells 58 and 60: Work as for Basic Shell 4.

Shells 59 and 63: Work as for Half Shell 2.

Shell 61: With larger needles and RS facing, pick up and knit 14 (16) sts down left edge of 58, and 1 st at top of 47—15 (17) sts. Work as for Half Circle, but k2tog at the beg of every WS row 4 times, beg on Row 3.

Shell 62: With larger needles and RS facing, pick up and knit 14 (16) sts down left edge of 60, 1 st at top of 58, and 10 (12) sts up right edge of 61—25 (29) sts. Work as for Basic Shell 4 through Row 10, but k2tog at the end of every RS row 5 times. Work Row 11 as follows: *For small size only:* K1, *k2tog, k2; rep from * to last 3 sts, k2tog, k1—15 sts rem. *For large size only:* *k2tog, k2; rep from * to last 4 sts, [k2tog] twice—17 sts rem.

Shell 64: Work as for Half Circle.

Shell 65: Work as for 61, picking up 1 st at top of 61.

• **Finishing:** With yarn threaded on a tapestry needle, sew the shoulders tog, matching shells. Sew right side seam by sewing the right sides of 16, 26, and 36 of the back to the gaps between 11, 21, 31, and 41 of the front. Sew left side seam in the same manner. **Neckband:** With mint, cir needle, RS facing, and beg at the left shoulder, pick up and knit 71 sts along the front neck as follows: 9 sts along shell 65, 1 st bet shells, 10 sts along shell 61, 1 st bet shells, 14 sts along shell 47, 1 st bet shells at center front, 14 sts along shell 48, 1 st

bet shells, 10 st along shell 52, 1 st bet shells, 9 sts along shell 56, then pick up and knit 29 sts along the back neck as follows: 14 sts along shell 65, 1 st at the center back, and 14 sts along shell 66—100 sts total. Do not join. With mint, knit 1 row (WS). With oyster, knit 2 rows. With ecru, knit 1 row. With ecru, p1, *yo, p2tog; rep from * to last st, p1. With ecru, work 4 rows St st. BO all sts loosely. With yarn threaded on a tapestry needle, sew the sides of the band tog. Fold the band to inside and stitch in place. **Armbands:** With mint, cir needle, RS facing, and beg at the underarm, pick up and knit 1 st at the underarm, 16 sts along the first shell, 14 sts along each of the next 2 shells, 1 st at the shoulder, 14 sts along each of the next 2 shells, and 16 sts along the rem shell—90 sts. Do not join. Work as for neckband, dec 10 sts evenly spaced to 80 sts on the first row. Weave in loose ends. Steam lightly.

JACKET

This jacket is worked the same as the top. But to make the lower edge straight instead of scalloped, triangles are worked between adjacent shells. If you wish, you can avoid sewing side and sleeve seams by working the jacket fronts and back in one piece and by working the shells in the sleeves in the round.

Triangle

With smaller needles and ecru, K-CO 11 (11) sts. Work Rows 16–30 (32) of Basic Shell 1.

•**Back:** Worked in the sequence, shapes, and color combinations shown on the Jacket Back chart. Work 1, 3, 5, 7, and 9 as Triangles; 2 as Basic Shell 2, but K-CO 21 (24) sts then pick up 8 (9) sts along right edge of Triangle—29 (33) sts; 4, 6, 8, and 10 as Basic Shell 4, but beg by picking up 8 (9) sts down left edge of one Triangle (with RS facing), turn, with WS facing, K-CO (13) 15 sts, turn, with RS facing, pick up 8 (9) sts up right edge of another Triangle—29 (33) sts; 11, 21, 31, 41, 51, 61, 62, and 76 as Basic Shell 3; 16, 26, 36, 46, 56, 68, and 69 as Basic Shell 2; 77 and 94 as Half Shell 1; 85 and 102 as Half Shell 2; 112–118 as Half Circle; and rem shells *except 111 and 119* as Basic Shell 4.

Shell 111: With larger needles and RS facing, pick up and knit 14 (16) sts down left edge of 110, and 1 st at top of 94—15

(17) sts. Work Rows 1–14 of Basic Shell 1—8 (9) sts rem.

Row 15: K2tog 4 times, k0 (1)—4 (5) sts rem.

Row 16: Knit.

Row 17: K2tog 2 (1) time(s), k3tog 0 (1) time—2 sts rem.

Row 18: K2tog. Cut yarn and pull tail through rem st.

Shell 119: Work as for shell 111, picking up 1 st at top of shell 102, and 14 (16) sts up right edge of shell 103.

•**Right Front:** Worked in the sequence, shapes, and color combinations shown on the Jacket Right Front chart. Work 1 and 3 as Triangles; 2 and 4 as 2 and 4 of back; 5, 10, 15, 20, 25, 30, 31, and 38 as Basic Shell 3; 7, 12, 17, 22, 27, 34, and 43 as Half Shell 2; 39 and 48 as Half Shell 1; 57 and 58 as Half Circle; and all rem shells *except 52, 56, and 59* as Basic Shell 4.

Shell 52: With larger needles and RS facing, pick up and knit 1 st at top of 44, and 14 (16) sts up the right edge of 51—15 (17) sts. Work as for Half Circle, but k2tog at the beg of every RS row 4 times. End Row 11 with 6 sts and end Row 15 with 3 sts. Next row: Sl 1, k2tog, psso.

Shell 56: Work as for 111 of back.

Shell 59: With larger needles and RS facing, pick up and knit 10 (12) sts down left edge of 52, 1 st at top of 51, and 14 (16) sts up right edge of 53—25 (29) sts. Work Rows 1–16 of Half Circle, but inc 1 st at the beg of every RS row 4 times—29 (33) sts, and work Rows 11 and 15 as follows:

Row 11: K2tog to last st, k1—15 (17) sts.

Row 15: K2tog to last st, k1—8 (9) sts.

Row 17: *For small size only:* *K2tog; rep from *—4 sts rem. BO all sts. *For large size only:* *K2tog; rep from * to last st, k1—5 sts rem. BO all sts.

•**Left Front:** Work as for Right Front in color combinations shown on the Jacket Left Front chart. Work 1 and 3 as Triangle; 2 and 4 as 2 and 4 of back; 5 as Basic Shell 3, but with RS facing, pick up and knit 8 (9) sts down left edge of 3, then K-CO 21 (24) sts; 6, 12, 18, 24, 30, 36, and 44 as Half Shell 1; 9, 15, 21, 27, 33, 39, and 40 as Basic Shell 2; 48 and 56 as Half Shell 2; 62 and 63 as Half Circle; and all rem shells *except 60, 61, and 64* as Basic Shell 4.

Shell 60: With larger needles and RS facing, pick up and knit 14 (16) sts down left edge of 53, and 1 st at top of 52—15 (17)

sts. Work as for Half Circle, but k2tog at the end of every RS row 4 times. End Row 11 with 6 sts and end Row 15 with 3 sts. Next row: Sl 1, k2tog, psso.

Shell 61: With larger needles and RS facing, pick up and knit 14 (16) sts down left edge of 59, 1 st at top of 53, and 10 (12) sts up right edge of 60—25 (29) sts. Work Rows 1–16 as for Half Circle, inc 1 st at the beg of every WS row 4 times—29 (33) sts, and working Rows 11 and 15 as follows:

Row 11: K2tog to last st, k1—15 (17) sts rem.

Row 15: K2tog to last st, k1—8 (9) sts rem.

Row 17: *For small size only:* *K2tog; rep from *—4 sts rem. *For large size only:* *K2tog; rep from * to last st, k1—5 sts rem. BO all sts.

Shell 64: Work as for shell 119 of back.

•**Finishing:** With yarn threaded on a tapestry needle, sew the shoulders tog, matching shell for shell. Sew right side seam by sewing the right sides of 2, 16, 26, 36, and 46 of the back to the gaps between 3, 5, 10, 15, 20 and 25 of the right front. Sew left side seam in the same manner.

Front and neckband: With oyster, longer cir needle, RS facing, and beg at right shoulder seam, pick up and knit 567 (605) sts around the jacket as follows: 34 sts across back neck, 29 (30) sts along left front neck, 98 (105) sts down left front, 22 (24) sts around shell 2 of left front, 235 (253) sts around lower edge to shell 5 of right front, 22 (24) sts around shell 5 of right front, 98 (105) sts up right front opening, 29 (30) sts along right front neck. Do not join. Knit 1 row, inc 2 sts at each neck corner and 3 sts at each lower front corner—10 sts inc'd. With pear, knit 1 row, working 7 buttonholes on right front in line with the corner stitches of shells 8, 13, 18, 23, 28, 35, and 44 as follows: k2tog, yo twice. With pear, knit the next row, inc 10 sts as before and knitting 1 st in each double yo from the previous row. With ecru, knit 2 rows, inc 10 sts as before in the first row. With hazel, knit 1 row. With hazel, BO all sts. Sew edges of band together. **Cuffs:** With oyster, shorter cir needle, RS facing, and beg at underarm, pick up and knit 76 (80) sts around lower sleeve edge. Do not join. Work as for front and neckband, but dec 5 sts evenly spaced on the second row. Sew edges of band together. ∞



Experience
Lambspun's *NEW*
Swatch Club™

Premiere Charter Membership
\$15.00/year-Six Issues...include

Five Exciting Yarns to Swatch • Newsletter
Original & Exclusive Patterns • Huge Savings!
And More!

Let Lambspun spark your creativity...



Twin Peaks

Join Now!!

By phone or mail...
Visa/MC accepted!

Lambspun of Colorado
1-800-558-5262

1101 E. Lincoln Ave., Dept. K • Fort Collins, CO 80524

Premiere Issue - Texture Me Elegant!

Swatch Club™
for Discerning Knitters

TESS' DESIGNER YARNS

Fine Fibers in Exceptional Colors
33 Strawberry Point, Steuben, Maine 04680 ~ tessyarns@mcimail.com



Right Angle Cardigan

Designed by Ginger Lutens, Available in Kits in
Gorgeous. Take Your Breath Away Hand Dyed Colors!
Phone: 800-321-TESS/207-546-2483 VISA/MC

Plunge In
You'll love Halcyon Yarn!

Discover a world of color & texture...
Our natural fiber yarns are top quality.

Expand your horizons...
With thousands of books, magazines
and instructional videos.

Shop at home...
Our mail order service is friendly,
reliable and affordable. Internet users
will find us at www.halcyonyarn.com.

Call today for a free sample card!
1-800-341-0282

**Halcyon
Yarn**

12 School St • Bath, ME 04530



SHUTTLES,



Weaving • Basketry • Spinning
Knitting • Classes

Mon 12-6pm • Tues-Sat 10-6pm
Closed Sundays

633 S. Broadway, Table Mesa Center
Boulder, Colorado

(303) 494-1071 • (800) 283-4163

SPINDLES & SKEINS



Carolina
Homespun

190 Eastridge Rd., Ridgeway, VA 24148
(540) 957-1174

e-mail: carolina_homespun@msn.com

Available
Now!

Anna Zilboorg's
**MAGNIFICENT
MITTENS Kits**

Visit our
booth at
**Stitches
West!**

...complete with hand dyed yarns (to Anna's specifications and recipes) and instructions.

The colors are rich and glowing, the mohair/merino blend yarn is gloriously lustrous and smooth, the angora lining yarn is delectable and the patterns for these gauntlet mittens are intricate, exciting, and—well, magnificent!

Color card, kit info: \$2

SPINNING - WEAVING - KNITTING - DYEING

Equipment, supplies, books, videos, and more!

Catalog: \$2

HAVE YOU TRIED OUR Euroflax LINEN

OR



MERINO WOOL YARNS YET?

Louët

Custom spun to our exacting specifications, using the finest natural fibers available.

Available coast to coast at over 1000 Louët dealers.

Louët Sales, Inc.

P.O. Box 267-KN

Ogdensburg NY 13669

613-925-4502

Dealer inquiries welcome





MAYAN SOCKS

JEAN MOSS

Comfortable cotton

Two colorways

FINISHED SIZE 9" (23 cm) from heel to toe; 7" (18 cm) from cuff to top of heel. To fit a woman's medium foot.

YARN Rowan 4-ply Cotton (100% cotton; 184 yd [168 m]/50 g): **Colorway A:** #111 rush (A), #110 straw (B), #105 blaze (C), #108 cobalt (D), #112 opaque (E), #109 monsoon (F), #102 marine (G), 1 ball each. **Colorway B:** #102 marine (A), #108 cobalt (B), #110 straw (C), #107 racey (D), #105 blaze (E), #112 opaque (F), #111 rush (G), 1 ball each.

NEEDLES Size 3 (3.25 mm): set of 4 double-pointed (dnp). Adjust needle size if necessary to obtain the correct gauge.

NOTIONS Marker; tapestry needle.

GAUGE 16 sts and 19 rnds = 2" (5 cm) in cir St st.

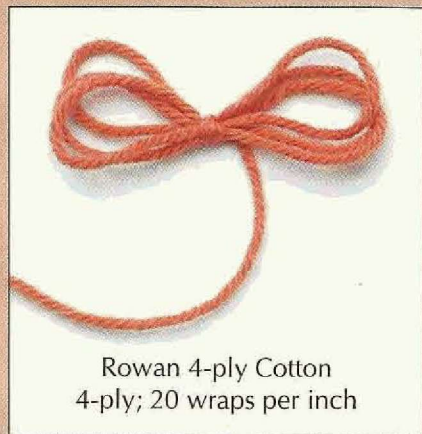

Rowan 4-ply Cotton
4-ply; 20 wraps per inch



THE DAZZLING embroidered weavings of the Guatemalan people were my inspiration for these Mayan Socks. I love the bold colors and striking geometric designs. It's so exciting to use these symbolic patterns which have been handed down over the centuries and to be able to continue the tradition of passing them on again. The first twenty rows are worked in intarsia and the rest in color stranding.

•**Leg:** With E and F tog, make a loop and place it over a needle (this loop does not figure in the total st count). Using the two-color method with F over the index finger and E over the thumb, CO 56 sts onto 1 dnp. When all sts have been CO, remove the loop made of the two colors. Divide the sts evenly onto 3 dnp. Place m and join, being careful not to twist sts.

Plaited edging: (Work very loosely.)

Rnd 1: *K1 with F, k1 with E; rep from *.

Rnd 2: Bring both yarns to front of work and keeping them in the same order as on the previous rnd, *p1 with F, p1 with E, always bringing the yarn to be used over the top of the yarn just used. Rep from *.

Rnd 3: *P1 with F, p1 with E, always bringing the yarn to be used under the yarn just used. Rep from *.

Rep these 3 rnds once more. Beg with Row

TWO-COLOR CAST-ON

Leaving tails about 4" (10 cm) long, tie the two yarns together in an overhand knot. With your right hand, hold the knot on top of the needle a short distance from the tip, then place one yarn over your index finger and the other over your thumb. Continue as for a long-tail cast-on (bring the needle up through the loop on your thumb, hook it around the yarn on your finger, and back through the loop on your thumb). The yarn held on your index finger will make the stitches on the needle, the yarn held on your thumb will make the horizontal ridge at the base of the cast-on row.

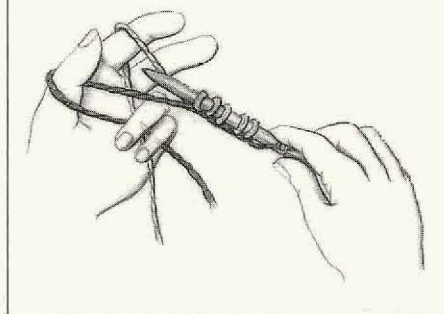

1, work to end of Chart 1. Then beg with Row 1, work to end of Chart 2, then work Rows 1–16 again.

•**Heel:** Place first 14 sts and last 14 sts of rnd onto 1 dpn for heel—28 sts. Place rem 28 sts onto another dpn to be used later for instep. **Heel flap:** Join B and work the 28 heel sts back and forth as follows:

Row 1: (RS) *K1, sl 1; rep from *.

Row 2: Purl.

Rep these 2 rows until flap measures 2" (5 cm), ending with a RS row. **Turn heel:** Cont with B, working a series of short rows as follows:

Row 1: P16, p2tog, p1, turn.

Row 2: Sl 1, k5, k2tog, k1, turn.

Row 3: Sl 1, purl to 1 st before gap, p2tog, p1, turn.

Row 4: Sl 1, knit to 1 st before gap, k2tog, k1, turn.

Cont in this manner, always working tog the 2 sts on each side of the gap, until all sts on both sides have been used—16 sts rem. On next row, k8. **Gussets:** With E and needle #1, knit rem 8 heel sts and then pick up and knit 14 sts along the left side of heel flap. With needle #2, work across 28 instep sts in patt. With needle #3, pick up and knit 14 sts along right side of heel flap and then knit 8 heel sts—72 sts (22 sts each on needles #1 and #3; 28 sts on needle #2). The rnd now begins at the back of the heel. Beg with Row 17 of Chart 2 and cont in patt, knit 1 rnd. On next rnd, knit to 3 sts from end of needle #1, k2tog, k1, then knit across 28 sts on needle #2, and then k1, ssk, knit to end

of needle #3—2 sts dec'd. Rep these 2 rnds, dec at the end of needle #1 and beg of needle #3 8 times total (16 rnds)—56 sts rem; 14 sts each on needles #1 and #3, and 28 sts on needle #2. *Note:* To maintain Rows 26–29 of the patt during these decs, work the 8-st patt rep twice, work the first 7 sts, work the last 2 sts, work the 8 sts 3 times, work the first 2 sts, work the last 7 sts, work the 8 sts twice. As you dec 8 times, gradually the extra 8 sts will dec to 7, 6, 5, etc., until after 16 rows you work the 8 sts 7 times.

•**Foot:** Cont following Chart 2 until piece measures 6" (15 cm) from gusset, being sure not to end in the middle of a 4-row Fair Isle patt.

•**Toe:** Join C. Knit to 3 sts from end of needle #1, k2tog, k1. K1, ssk, work to 3 sts from end of needle #2, k2tog, k1. K1, ssk at beg of needle #3, knit to end. Knit 4 rnds even. Dec in the next rnd as before. Knit 3 rnds even. Dec in the next rnd. Knit 2 rnds even. *Dec in the next rnd. Knit 1 rnd. Rep from * once. Dec in the next 6 rnds—6 sts on needle #2; 3 sts each on needles #1 and #3. With needle #3, knit across sts on needle #1.

•**Finishing:** Cut yarn, leaving 20" (51 cm) tail for grafting. With yarn threaded on a tapestry needle, use Kitchener st (see Glossary, page 6) to graft toe sts tog. Weave in loose ends. Block. ☞

Jean Moss, author of *The Jean Moss Book of World Knits* (Taunton Press, 1997), lives in York, England, where she teaches and designs knitwear.

WORKING INVISIBLE "SEAMS"

KNITTING COLOR stripes in the round can result in jogs at the "seam" line. Meg Swansen has come up with an ingenious technique for eliminating these jogs and creating invisible "seams". Here's a modified version of her technique.

Let's say you've been knitting with color A and want to knit a stripe with color B. Drop A and work to the end of the round with B, and then (here's the important part) work the first stitch of the round again with B by knitting into the stitch below the stitch on the needle, letting the stitch on the needle drop off. You have worked the first stitch of the round twice, but because you work into the stitch below the one on the needle the second time, you have only worked it for one round and it appears as if it were worked just once. The jog between the two colors disappears and the beginning of the round is shifted one stitch to the left. Continue working as many rounds as you want with color B. To change to another color, simply repeat the process, working the first stitch of the round a second time by knitting into the stitch below the one on the needle (and letting the stitch on the needle drop off), thereby shifting the beginning of the round one more stitch to the left.

This trick also works for multiple color patterns. As the color shifts, note that this stitch will not necessarily be worked with the same color both times.

Because each round is worked as a complete circle, this trick results in concentric rings of stitches instead of a continuous spiral. Therefore, a round can begin at any stitch. When it comes time to work shaping (such as a heel) that requires the round to begin at a specific place in the color pattern, begin the shaping wherever you want by simply shifting the stitches on the needles and joining a new yarn.

For more details on jogless knitting, see Meg's article "The Jogless Jog" in *Knitter's Magazine*, Winter 1996.

Colorway A (Colorway B)

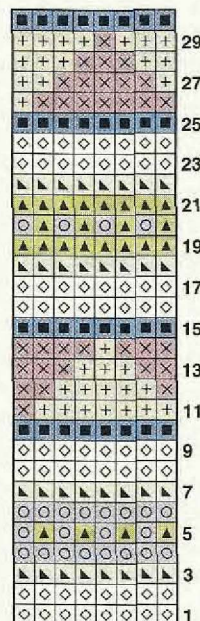
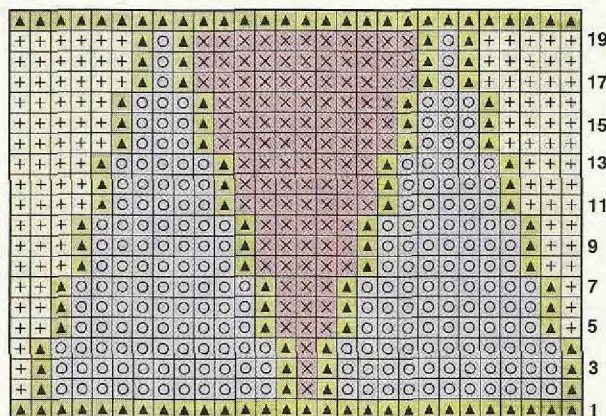
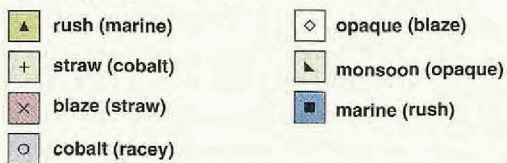



4 Green Hill Rd. • P.O. Box 504
Washington Depot, CT 06794

Specializing in natural fiber yarns
for knitting from the following:

- Rowan
 - Tahki/Stahl
 - Lane Borgosesia
 - Plymouth/Cleckheaton
 - Anny Blatt
 - Grignasco
 - Brown Sheep
 - Classic Elite
 - Skacel
 - Berroco
 - Sirdar
 - Katia
 - Noro
 - Muench
- and more!

And . . . hand painted needlepoint from
the country's leading designers, with a
complete selection of fibers, including
Persian wools, silks, cottons, metallics
and novelty fibers.

Expert Finishing Services Available. Call for
more information and our free brochure

1-800-371-1014

Featheridge Designs

4 Green Hill Rd. Washington Depot, CT 06794
Tues.-Sat. 10-5 • MC/VISA/DISC.



MOUNTAIN COLORS

HAND-PAINTED YARNS

*Bring the rich and varied colors of a mountain sunset,
a high mountain meadow or a pristine alpine lake
into your knitted creations.*

P.O. Box 156 Corvallis, Montana 59828
Phone (406) 777-3377 Fax (406) 777-7313

Hand Painted
Yarns
in Wool, Mohair
& Novelty Fibers

26 Colorways

Color Card &
Brochure \$7 ppd



An Adventure in Intarsia Knitting

Sweaterscapes for every kind of knitter

We also offer simple solid color & textured
sweaters, landscape sock kits, and books.
Reasonably priced wool yarn kits.

Ask for our free color catalog
or visit our complete on-line catalog at
www.cybertours.com/borealis

Borealis Sweaterscapes

95 Hessian Hill Road, Cornish, ME 04020
207-625-8955 • borealis@cybertours.com

Don't use
a million pins
when you
block!

Just insert
these rustproof,
stainless Blockers
along the edge of
your unfinished
knitted pieces.

The Blockers
stop the curling
and smooth the
knitted fabric so
you can easily
pin and steam to
your desired
measurements.

**\$18.50
plus \$3.95 sh**

Blockers Kit includes:

- 8 (36") & 4 (18") rigid Blockers
- 2 flexible 27" blockers for curves.
- 1 cm/in yard stick • 30 T-pins
- Blocking instructions

**Fiber Fantasy Knitting
Products Ltd.**

6 Hunters Horn Court
Owings Mills, MD 21117
1-800-242-Knit (5648)

Visa • Mastercard • Discover • Am Exp

ROWAN yarns

A World Of Color At Your Fingertips

Rowan Spring/Summer Magazine #23

Featuring over 30 new designs
by top British designers,
Kaffe Fassett, Kim Hargreaves,
Louisa Harding and Martin Storey.

For the nearest fine shops carrying
the Rowan Pattern books,
yarn and knitting kits,
please contact:

Westminster Fibers
5 Northern Boulevard
Amherst, NH 03031
(603) 886-5041

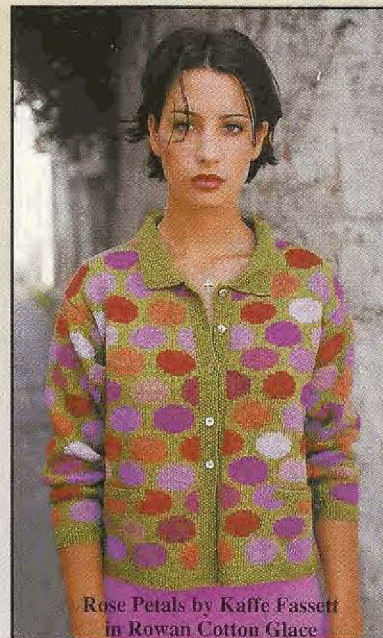

Rose Petals by Kaffe Fassett
in Rowan Cotton Glace

YARN COLLECTOR'S SWEATERS

Sharon O'Brien

ALTHOUGH VIEWED by some as a bad habit, yarn collecting, I think, is a very useful hobby. With so many gorgeous yarns available, it's easy to want at least one skein of everything. One ball of this and one ball of that can quickly add up to a sweater's worth (or closetful).

graphs from your travels, and views from your window can provide inspiration for color and texture. The sky at dusk, striped with clouds and layers of deepening blues, provided the inspiration for my Blue Evening Cardigan. Bits of metallic yarn and bright, textured novelty yarns suggest stars beginning to appear in the evening sky.

Art also provides wonderful color inspiration. Monet's pastel combination of blue, mint green, and lavender works beautifully in a mohair and wool sweater.

A single ball of multi-color yarn can also provide stimulus. This "inspiration yarn" can be commercially bought or your own beautiful handspun, and you may use a lot or a little of it in your garment. Tahki's (Stahl's) "Limbo" color yarn, Classic Elite's "Fame", Brown Sheep

Company's "Handpaint Originals", and Berroco's "Europa" are good examples of inspiration yarns.

Other aids for choosing color are yarn color cards and paint sample cards. Yarn companies supply color cards of their yarns to retail yarn shops. The arrangement of the colors on these cards is well planned, often making it easy to see which colors work well together. You may ask to look at these color cards at your local yarn shop.

The arrangement of colors on paint sample cards is also well planned. If you are looking for a specific shade of purple yarn, you could find the color on a paint sample card and take it to your yarn store to make the color hunt easier.

Fabric also provides valuable information on blending colors; you could use the colors in a piece of cloth as your color theme.

Once you have chosen your yarn colors, collect a pillowcase full of them. Include yarns with texture, spaced-dyed yarns, heathers, and tweeds. You can include varying thicknesses, but thin yarns may have to be doubled or tripled to achieve the gauge of thicker ones.

If you are working with red and purple, you could stray from your color theme by finding a red or purple space-dyed yarn that includes some surprise colors, perhaps a small area of orange or green. Or you could use a red or purple tweed yarn that con-



Monet Jacket. The subtle vertical stripes in this cuff-to-cuff style can be very flattering.

Sweaters made from such a collection need not be a mass of odd stripes or patches of different colors. Seemingly unrelated yarns can be subtly blended to become a unique and beautiful garment. To successfully mix different yarns, follow these few simple guidelines. First, choose a color scheme. Second, know your fibers and test-knit yarns and colors together. Third, use simple garment designs and stitch patterns. And finally, be neat.

CHOOSE A COLOR SCHEME

Beautiful color combinations are everywhere, and nature provides some of the best. Nature photography books, photo-



The Colorado Sweater. This was inspired by a (discontinued) Tahki/Stahl yarn. In this yarn, a wool strand with blues ranging from aqua to deep purple-blue was plied with a dark bouclé strand. The bands of color in the sweater mimic the colors of the wool ply; the garnet edging was derived from the dark garnet color in the bouclé ply. The inspiration yarn appears as the contrasting stitch knitted into the bands of blue, green, and periwinkle.

tains bright yellow or aqua dots. These small bits of contrasting colors will keep your garment from becoming too well blended and monochromatic.

KNOW YOUR FIBERS

When combining many different yarns in a garment, it is important to have some knowledge of the fibers and yarn construction. *Principles of Knitting* by June Hemmons Hiatt contains an excellent section on fibers, and magazines and books on spinning also provide a wealth of fiber information. Experience is also a great teacher; keep a notebook about problems and successes you have had with various yarns.

Always use quality yarns in your hand-knit garments. A sweater that involves your time, creativity, and money should last for a long time. In general, yarns with similar fiber contents blend better than widely different fibers. A crisp cotton may

stitches per inch, they can look thin when knitted with other bulky yarns such as Icelandic wool. Fatten up mohair by knitting it together with fine wool or a lace-weight mohair. Also, mohair should be knitted more tightly to work successfully in a worsted-weight sweater of approximately $4\frac{1}{2}$ stitches per inch.

Use cotton with other cellulose fibers such as linen and rayon. Cotton also works well with blends containing silk or synthetics. Cotton is a smooth fiber; it lacks the crimp and scales that give wool its resiliency. Long staple (such as Egyptian), mercerized, and multi-ply cotton yarns are less likely to pill and lose their shape than chalky-feeling cottons.

If you use cotton chenille, remember to knit tight. Cotton chenille that has a gauge recommendation of $3\frac{1}{2}$ to 4 stitches per inch can be used at 4 to possibly $4\frac{1}{4}$ stitches per inch in a mixed cotton sweater. The scattered rows of cotton chenille will have a slightly raised texture which will add interest to the overall look of the garment.

Cotton garments, especially those containing some tightly knitted cotton chenille, can feel heavy; choose a style that can accommodate heavy fabrics, such as a short jacket, possibly with $\frac{3}{4}$ length or shorter sleeves.

Another problem with using many different cotton yarns in one garment is all those cut ends. Cut ends of mohair and wool hold well when hidden on the inside of a garment because fibers are scaled and crimped. But the cut ends of cotton, linen, and silk tend to slide out. To help solve this problem, leave long ends and make a small knot in them.

I also recommend that you avoid rayon chenille and other slick rayons unless you're combining them with other yarns. Rayon chenille can be knitted by itself but it must be knit at a tight, inflexible gauge that traps the stitches. It also tends to bias unless it is knit in a textured stitch (as opposed to stockinette). Even when knitted along with sticky mohair, rayon chenille stitches may

slide out of place. Also, 100 percent rayon yarn that looks like silk may stretch, and its cut ends will never stay in place without your retying knots nearly every time you wear the sweater.

Avoid using mill ends of unknown fiber content and age in your yarn collector's sweater. If you don't know what a yarn is, you won't know how to best care for it. Also, old yarn may have been damaged by insects, mildew, or being stored in a hot, dry place. This damage may not be readily apparent but reveal itself after several uses and washings of the garment.

Be cautious of "dry clean only" yarns. "Only" indicates yarn that may be too temperamental to mix with other yarns (even if you plan to dry clean the finished garment). Some yarns that the manufacturer recommends be dry cleaned can actually be gently hand washed. Test-wash a swatch of the yarn to see if it survives. Does the color bleed too much, does the yarn sag and pill? Care of the finished garment should be determined by its most sensitive yarn.

Also be cautious of acrylic chenilles and other acrylics. Does the acrylic chenille shed? Other 100 percent acrylic yarns just may not blend well in a mostly wool or mostly cotton sweater. Also keep in mind that some synthetic yarns may pill, or sag, and some may *require* machine washing and drying to regain their shape.

On the other hand, a yarn collector's sweater gives you the opportunity to use yarns you might otherwise avoid. These include your less-than-favorite colors such as bile green and road-crew orange and novelties such as glitz and eyelash. Bits of intense color and/or texture carefully



Berries and Kiwi Cardigan. A hand-dyed yarn of fruit-punch red, kiwi green, and tangerine orange adds even more interest to the main colors of rich reds and purples.

stand out too much and look out of place in a mostly wool sweater. Also, similar fibers will have similar care and washing requirements. Lastly, in choosing assorted yarns for a color-blended project, consider comfort and intended use. A row or two of prickly mohair in a mostly cotton summer jacket may drive you crazy when you wear it over a sleeveless blouse.

Use wool with other animal fibers including angora, cashmere, alpaca, and mohair. Be cautious about mohair yarns; even though many mohair yarns are considered "bulky" because of their gauge of $3\frac{1}{2}$ to 4



Valentine's Day Jacket. Colors for this jacket were chosen from a brightly colored silk fabric. The silk was also cut into a continuous $\frac{1}{2}$ -inch-wide strip and knitted into the jacket.

placed can liven up a sweater, as seen with the Fame yarn in the Blue Evening Cardigan. To add a touch of sparkle to a garment, use novelty yarns with cotton or wool. Also consider weaving thrums, cotton embroidery floss, and needlepoint wool for your sweater. Just remember that small yarn scraps should be three to four times the width of the row you are about to knit to avoid running out and having to knot and join a new yarn mid-row.

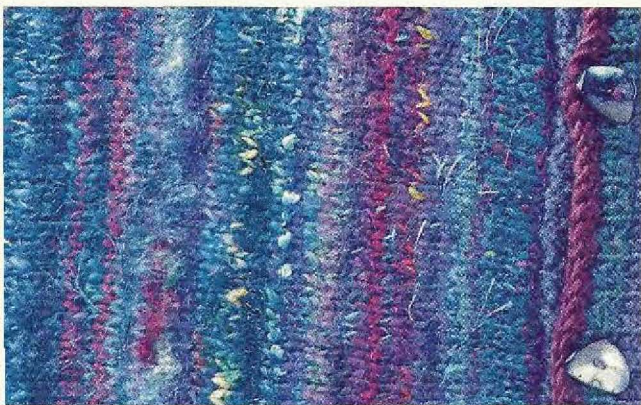

Blue Evening Cardigan. This sweater seemed too monochromatic until I livened it up with the tropical fruit colors of my favorite Fame from Classic Elite.

CHOOSE SIMPLE GARMENT DESIGNS

Drop shoulder pullovers are the easiest to make so I recommend them for experimenting with color and texture. Basic patterns that include schematic drawings with measurements are most useful. Paton's *Back to Basics* pattern booklets come in three volumes, one for each yarn gauge: sport, worsted, and chunky. These booklets contain a broad range of sizes: child size 2 to extra large adult size 54. Drop-shoulder garments may look oversized and sloppy, so you should choose which size to knit according to "actual finished measurements" listed in the pattern. Pullovers with indented sleeves are also easy to do, and the top of the sleeve sits up closer to your shoulder.

Because stitch and row gauge can be somewhat unpredictable when you use many different yarns, use the schematic drawings as a guide and measure your sweater frequently as you knit. You could even draw full-size pattern pieces on large sheets of paper and, as you knit, match your

knitting to these paper pieces. My "Blue Patchwork Jacket" was designed this way.

If you are an experienced knitter, you may want to try a pullover knit in the round from the top down using Barbara G. Walker's book *Knitting from the Top*. Use flattering novelty yarns and colors in the yoke. Knitting from the top allows you to try on the yoke as you knit to be sure of fit.

Sweaters that are knitted from one cuff across the body to the other cuff are great for blending many different yarns. Subtle vertical stripes in this cuff-to-cuff style can be very flattering. Row gauge plays an important part in sleeve length and body width. Remember to measure often as you knit, and compare to your schematic drawings.

Raglan styles are the most challenging to re-design, but if you do want to knit this style sweater, keep in mind that yarns such as alpaca and slippery silk may elongate row gauge, and tightly-knit cotton chenille may shorten row gauge—unpredictable row gauge can distort raglan shaping and create disaster in your sweater.

USE SIMPLE STITCH PATTERNS AND BE NEAT

Working with many yarns in one garment does not need to involve a tangled mess with lots of loose ends. A little planning and some common sense can make your garment a fun work of art.

I recommend knitting on circular needles, even when knitting back and forth (not in the round). If the cobalt yarn you want to use in the next row is stuck next to the stopper of a straight needle, you'll have to cut and retie the cobalt to work the next row. Circular needles allow you to push stitches to the other end of the needle, helping you to avoid unnecessary cuts and extra loose ends to work in. Using simple stitches, such as stockinette, allows you to "read" your fabric. For example, if pushing the cobalt yarn to the other end of your circular needle leaves the purl side of your stockinette facing you (even though you've just finished purling a row

of periwinkle), common sense tells you to purl your next row in cobalt.

Garter stitch, moss, seed, or other simple knit/purl combinations blend color well. Stockinette stitch makes a pretty fabric, but more thought is needed in order to blend well without harsh stripes. Slip-stitch patterns, woven stitch, and stranding two colors across a row are other ways to mix colors. Several simple pattern stitches could be alternated randomly in one garment. When using stockinette stitch, work the nubs in textured or novelty yarn so that they will pop out on the right side of your garment. (That is, purl the nub when the "knit side" of the fabric faces, or knit the nub when the "purl side" faces.)

Be neat by working cut tails in as you knit; this is less daunting than working in a lot of cut ends when the knitting is



Blue Patchwork Sweater. The front of the sweater was the most challenging and fun part to knit and so was done first. The knitting became a bit tiring, so the back was done in a simple moss stitch. By the time I got to the sleeves, I was ready to move on to another project, so they're done in quick and easy stockinette stitch. A crocheted edging was an easy way to finish the front opening.

completed. However, working tails in as you go can be a problem if you decide to rip something out; those hidden cut ends prevent easy ripping.

GETTING STARTED

First assemble yarns in toy train fashion, placing one yarn after another, end to end. Squint, or use a "value finder" to help you arrange colors in the order that they are to be used. A value finder is a piece of colored plastic that you look through to see dark and light contrast; it can be found in quilting supply stores. Arrange colors with some light and dark contrast, otherwise a row of cornflower blue next to a row of lilac may blend and appear as two rows of periwinkle. Avoid extremes in dark/light contrasts unless you want a zebra striped effect. Glance at the train of yarn, and rearrange colors until you have the desired arrangement.

I generally use colors in spectrum order: red, orange, yellow, green, blue, violet. Shift back and forth across the spectrum as desired to enhance the flow of colors. This subtle shift in both value and color blends the different yarns in a watercolor manner instead of a random muddy blending.

After assembling your yarns in the order that they are to be used, work up a generous swatch, six to ten inches square. A large swatch will help you weed out problems such as a wrong color, a color in the wrong place, a yarn too thick or too thin. If a very expensive yarn is getting lost in the fabric it is wasted; save it for some other project. Remember to use your prettiest yarns near your face, around necklines and front button openings, or near the cuffs. Expensive novelties strategically placed in small amounts become "jewelry" in your sweater. A \$17 ball of novelty yarn doesn't seem so expensive when it is used in four of your one-of-a-kind sweaters.

When you are ready to begin your garment, cast on with waste contrast yarn using the invisible cast on (see page 43). There are several reasons for keeping an open cast-on row. First, the bands of your sweater are like a picture frame—they pull the whole work of art together and highlight it. It's easier to choose the right yarns to frame the edges of your sweater at the end of the knitting. On a practical level, if there is any problem with row gauge, open cast-on edges leave you an easy way out. A few rows of

single crochet can stabilize a sleeve bottom without adding excess fabric on sleeves that are already too long. If the sleeve or body of the sweater is too short, you can add rows before knitting ribbed cuffs or borders.

Be asymmetrical in the arrangement of your yarns and colors. As long as the yarns you choose all fit into your color scheme, you need not worry about running out. If you do run out of the gold yarn you used near the cuff of your first sleeve, just find some other gold yarn to use near the cuff of the second sleeve. If you get tired of the stitches you used on the fronts of a cardigan, you can change to a different stitch for the back and sleeves. This change of stitch pattern will require use of a paper guide as you knit to ensure the sweater pieces will fit together.

Stop and evaluate as you knit. If you think you may have made an error in the neck shaping, stop and count the stitches and fix the problem early. Don't say, "I'll give it a few more rows and see how it looks." If you don't like a particular small area of color, you could duplicate-stitch over a row or two when you're finished rather than rip.

If you are knitting several strands together (treating them as one yarn), make a guide on an index card as a quick reference. For instance, suppose the core yarn of your sweater is Icelandic wool and the average gauge you are knitting is $3\frac{1}{4}$ stitches per inch. Tape a length of this yarn onto a large index card, being careful to maintain the twist that was put in the yarn as it was spun. Then lightly twist together the several finer yarns you plan to knit together as one yarn. Cut and tape a length of this "new yarn" next to your Icelandic wool to see if it is the same thickness. If so, it will probably knit to about the same gauge.

It is easier to do multicolor knitting if you have only two or three yarns going at a time. When knitting back and forth, turn your work clockwise, then counterclockwise; otherwise the three yarns you are using will get spun into a big mess. Placing individual balls of yarn in separate tote bags

or boxes can help prevent tangles, too.

Plan your yarn changes before you cut, and change only one color at a time. For example, say you are knitting with three separate balls of yarn. You have knitted one row of green followed by one row of blue followed by one row of purple. Cut the blue and work in the cut ends. When you reach

*It is easier to do multicolor
knitting if you have only two or three
yarns going at a time.*

the other end of the row tie on a new color of yarn, or just continue to alternate the green and purple for several rows. Alternate the sides at which you cut and tie in yarns. Whenever possible, strand the yarns up the sides of the knitting if there will be $\frac{1}{2}$ to 1 inch or more between rows knitted of one yarn. Also strand or alternate colors across shoulder bind offs. For instance, knit one stitch blue, one stitch green, bind off one, knit one stitch blue, bind off one, knit one stitch green, et cetera.

Using up "leftovers" should never be the primary goal when knitting a color-blended sweater. You need a good assortment of space-dyed and multicolored yarns in order to help your stash yarns work well together. You may find yourself seeking out more and prettier yarns to go into your one-of-a-kind creation, thereby perpetuating more leftovers. You will, however, have fun learning about color and creating a truly unique wearable work of art. Experiment with these techniques by knitting pillows such as those on the following pages. ∞

SOURCES

- Back to Basics*, volumes I, II, and III. Toronto, Canada: Coats Patons-Coats Canada Inc., 1992.
- Hiatt, June Hemmons. *The Principles of Knitting*. New York: Simon and Schuster, 1988.
- Walker, Barbara G. *Knitting from the Top*. Pittsville, Wisconsin: Schoolhouse Press, 1996.



YARN COLLECTOR'S PILLOWS

SHARON O'BRIEN

Quick knitting • Small amounts of many colors

FINISHED SIZE About 18" (46 cm) square.

YARN Berroco yarns: Chloe (78% rayon, 22% mohair; 120 yd [111 m]/50 g): #3362 violet for dark pillow, #3222 bluebell for light pillow (MC), 4 skeins; Chinchilla (100% rayon; 77 yd [71 m]/50 g): #5334 black for dark pillow, #5422 plum for light pillow, 1 ball; Electra (66% wool, 34% nylon; 108 yd [100 m]/50 g): #6106 peacock, 1 ball; Glacé (100% rayon; 75 yd [69 m]/50 g): #2356 teal, #2420 petunia, #2422 plum, 1 skein each; Mohair Classic (78% mohair, 13% wool, 9% nylon; 93 yd [85 m]/50 g): #A7903 violet, #B1110 dark lavender, #B1116 rose, 1 ball each; Mohair Classic Heather (78% mohair, 13% wool, 9% nylon; 93 yd [85 m]/50 g): #A7918 turquoise, #A9543 magenta, 1 ball each; Phoebe (56% wool, 26.5% rayon, 17.5% nylon; 120 yd [111 m]/50 g): #7089 berry, #7088 lagoon, 1 ball each.

NEEDLES Border—Size 4 (3.5 mm): 16" or 24" (40 or 60 cm) circular (cir); Main Body—Size 6 (4 mm): 16" or 24" (40 or 60 cm) cir. Adjust needle sizes if necessary to obtain correct gauge.

NOTIONS Size F/5 (3.75 mm) crochet hook (optional); tapestry needle; four 7/8" (2.2 cm) buttons for each; 18" (46 cm) square pillow form for each.

GAUGE 18 sts and 26 rows = 4" (10 cm) with mohair in St st on larger needles; 19 sts and 40 rows = 4" (10 cm) in pattern st.

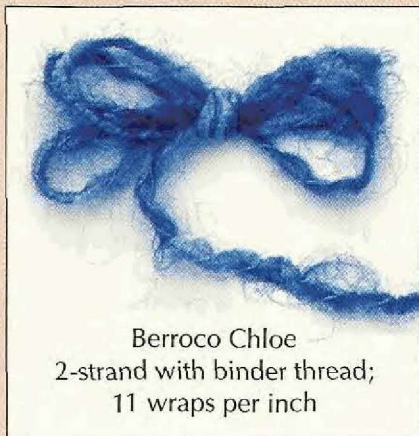

Berroco Chloe
2-strand with binder thread;
11 wraps per inch

A VARIETY OF COLORS, fibers, and textures are combined in these pillows. The colors flow from purple to blue to purple to red, and so on in chenille, mohair, wool blends, and rayon. Knitted more tightly than usual, the mohair appears plush and the fabric is dense and stable. Although many yarns are used in these pillows, only one is used at any one time.

The modified version of basket stitch is easily worked in garter and slip stitches for four rows followed by stockinette stitch for two rows. It must be worked on a circular needle so that cut ends can be divided evenly between both sides of the pillow. If all color changes were made along one side, a bulky, distorted edge would result.

Note: When the main color (MC) yarn is not in use, carry it up the side of the knitting. Because there are so many changes in the contrast colors, you may want to work in the ends as you go.

Stitch

Modified Basket Stitch: (multiple of 4 sts plus 3)
Worked on circular needle.

Set-up Row: (WS) With MC, purl.

Row 1: (RS) Join B. With B, k3, *sl 1 wyb, k3; rep from *.

Row 2: With B, k3, *sl 1 wyf, k3; rep from *. Cut B.

Row 3: Slide sts to other end of needle. Join C. P3, *sl 1 wyf, p3; rep from *.

Row 4: With C, p3, *sl 1 wyb, p3; rep from *. Cut C.

Row 5: Slide sts to other end of needle. With MC, knit.

Row 6: With MC, purl.

Rep Rows 1–6 for pattern, changing colors B and C with each rep as listed in box.

•**Front:** With MC and smaller needle, loosely CO 79 sts. Work Garter st (knit every row) for 9 rows. Change to larger needle and beg with set-up row, work Modified Basket st, foll color sequence until a total of 26 reps have been worked. Then work Rows 1–5 again. Change to smaller needle and MC and work Garter st for 9 rows. BO all sts loosely.

•**Back: Lower half:** Work as for front for a total of 11 reps of Modified Basket st. Then work Rows 1–5 again. **Button band:** Change to smaller needle and MC and work Garter st for 13 rows. BO all sts loosely. **Upper half:** With MC and smaller needle, loosely CO 79 sts. Work Garter st for 6 rows. **Buttonhole row:** [K14, BO 2 sts] twice, k15, [BO 2 sts, k14] twice. On next row, CO 2 sts over the BO sts. Cont in Garter st until a total of 13 rows have been worked from beg. Change to larger needle and work Modified Basket st as for back lower half. Change to smaller needle and work Garter st for 9 rows.

•**Finishing: Front Side Bands:** With MC, smaller needle, and RS facing, pick up and knit 89 sts along one side edge. Work Garter st for 9 rows. BO all sts



loosely. Rep for other side. **Back Side Bands:** Place buttonhole band over button band. Temporarily pin the buttonhole band to the button band to prevent the two pieces from twisting. With a tapestry needle threaded with MC, sew the buttonhole band to the button band at both edges of the overlap. With MC, smaller needle, and RS facing, pick up and knit 89 sts along the side edge. Work garter st for 9 rows. BO all sts loosely. **Assembly:** With yarn threaded on a tapestry needle and WS tog, sew pillow front to back along inner edge of the Garter st borders (the borders will be unattached at this point). Sew outer edges of borders tog. Mark placement of four buttons and sew buttons in place. Weave in all loose ends. Insert pillow form and button to close. ☞

When she was fourteen years old, Sharon O'Brien taught herself to knit using two steel crochet hooks, cotton yarn, and a how-to-knit book. Since then she's learned a lot about knitting and other fiber crafts. She currently resides in Ellicott City, Maryland.

COLOR SEQUENCE	COLOR B	COLOR C
1	Phoebe berry	Glacé teal
2	Phoebe lagoon	Mohair turquoise
3	Mohair violet	Electra peacock
4	Glacé petunia	Mohair rose
5	Phoebe berry	Mohair magenta
6	Electra peacock	Mohair dark lavender
7	Phoebe lagoon	Mohair turquoise
8	Phoebe berry	Chinchilla black
9	Electra peacock	Mohair violet
10	Glacé plum	Mohair magenta
11	Mohair violet	Mohair rose
12	Electra peacock	Mohair dark lavender

Repeat this sequence of 12 colors for color pattern.



STAINED-GLASS TUNIC

SARAH SWETT

Contrast of texture

Serendipitous color

FINISHED SIZE 39 (43, 48, 53)" (99 [109, 122, 134.5] cm) bust/chest circumference. Sweater shown measures 43" (109 cm).

YARN Muench GGH Rodina (100% cotton; 109 yd [100 m]/50 g): #34 beige (MC), 16 (17, 19, 21) balls. Muench GGH Cotton Velours (100% cotton; 145 yd [133 m]/50 g): #12 lavender, #18 lime green, #19 dark green, #30 teal, #35 blue, #38 pumpkin, 1 ball each.

NEEDLES Body and Sleeves—Size 4 (3.5 mm); Borders and Edges—Size 3 (3.25 mm). Adjust needle sizes if necessary to obtain the correct gauge.

NOTIONS Marker (m); six stitch holders; tapestry needle.

GAUGE 24 sts and 36 rows = 4" (10 cm) in color patterns on smaller needles; 24 sts and 32 rows = 4" (10 cm) in Bramble st on larger needles.



Muench GGH Rodina
2-ply 3 strand, 4-ply
16 wraps per inch

IN THIS SWEATER, color bursts forth from within the cables, evoking the look of stained glass. The pattern can work in many colorways: as a play of dark against light, warm against cool, or simply as a showcase for favorite colors and leftover bits of yarn. Texture is also a feature; the polished mercerized cotton contrasts nicely with the fuzzy chenille.

The front and back are worked separately and are joined at the shoulder by a strap worked from the neck to the arm opening. At the end of the strap, stitches are picked up along the edge of the front and back, and each sleeve is knit downward to the cuff. Although the sleeves may be knit from the cuff upward, the shoulder-to-cuff method makes a perfectly smooth join between the sleeve, shoulder strap, and body.

Part of this garment's excitement is the serendipity of color placement. Whenever a contrast color is mentioned, choose whichever color you want.

Stitches

Bobble Border: (multiple of 10 sts plus 1)
Row 1: (RS) P5, *(k1, p1, k1, p1) in next st, [turn, k4] 3 times, turn and lift 2nd, 3rd, and 4th sts over 1st st (one at a time) and off left needle, k1 (the rem st of group just worked), p9; rep from *, ending last rep p5.

Row 2 and all other WS rows: Purl.

Row 3: P1, *yo, p2, p2tog, k1, p2tog, p2, yo, p1; rep from *.

Row 5: P2, *yo, p1, p2tog, k1, p2tog, p1, yo, p3; rep from *, end last rep p2.

Row 7: P3, *yo, p2tog, k1, p2tog, yo, p5; rep from *, end last rep p3.

Rows 8, 9, and 10: Purl.

Bramble: (multiple of 4 sts)

Rows 1 and 3: (RS) Purl.

Row 2: *P3tog, (k1, p1, k1) in next st; rep from *.

Row 4: *(K1, p1, k1) in next st, p3tog; rep from *.

Rep Rows 1–4 for pattern.

•**Back:** With MC and smaller needles, CO 101 (111, 131, 141) sts. Work Bobble Border. Change to a CC and knit 2 rows (1 garter st ridge). Change to MC and knit 1 row, inc 19 sts evenly spaced—120 (130, 150, 160) sts. Purl 1 row. Beg with Row 1, work to end of Leaves chart. With MC, work 2 rows St st. With a different CC, purl 2 rows (1 garter st ridge). With MC,

purl 1 row, inc 14 (20, 16, 22) sts evenly spaced—134 (150, 166, 182) sts. *Set-up row:* Change to larger needles and beg with Row 1 of all patts, work 1 edge st, work Bramble over 8 (16, 24, 32) sts, p2, work Braid chart over 8 sts, p2, work Cherries chart over 12 sts, p2, work Bramble over 20 sts, p2, work Color Cable chart over 20 sts (using CC as desired), p2, work Bramble over 20 sts, p2, work Cherries chart over 12 sts, p2, work Braid chart over 8 sts, p2, work Bramble over 8 (16, 24, 32) sts, work 1 edge st. Work patt as established until piece measures 23 (24½, 26, 26)" (58.5 [62.5, 66, 66] cm) from beg. Divide sts onto 3 holders—41 (49, 57, 65) sts for each shoulder and 52 sts for back neck.

•**Front:** Work as for back through second garter st ridge. With MC, purl 1 row, inc 18 (24, 20, 26) sts evenly spaced—138 (154, 170, 186) sts. *Set-up row:* Change to larger needles and beg with Row 1 of all patts, work 1 edge st, work Bramble over 8 (16, 24, 32) sts, p2, work Braid over 8 sts, p2, work Cherries over 12 sts, p2, work Bramble over 16 sts, p2, work Braid over 8 sts, p2, work Cherries over 12 sts, p2, work Braid over 8 sts, p2, work Bramble over 8 (16, 24, 32) sts, work 1 edge st. Work patt as established until Cherries chart has been worked 5 (6, 7, 7) times total, ending with a WS row. Piece should measure 6¼ (7¼, 9¼, 9¼)" (16 [19.5, 23.5, 23.5] cm) from set-up row. **Divide for center panel:** Cont in established patt across 35 (43, 51, 59) sts. With a CC, k68 sts, turn. Knit the same 68 sts to form 1 garter ridge, turn. With MC, knit the same 68 sts, inc 5 sts evenly spaced—73 sts, then work rem 35 (43, 51, 59) sts in established patt. Cont working first and last 35 (43, 51, 59) sts as established and work the 73 center sts as follows: Purl 1 row. Work to end of Pine Needles chart, work 2 rows St st, knit these 73 sts only for 2 rows (1 garter ridge) in a different CC, pick up MC and while knitting across center sts, [M1] 4 times in first 16 sts, k40, [M1] 3 times in next 16 sts—80 center sts. On next RS row, work Color Cable chart on first and last 20 center sts and work Spiral chart on rem center 40 sts. When chart is complete, work 2 rows St st. Then with another CC, work 2 rows (1 ridge) of garter st on center 40 sts above color patterns. Work in

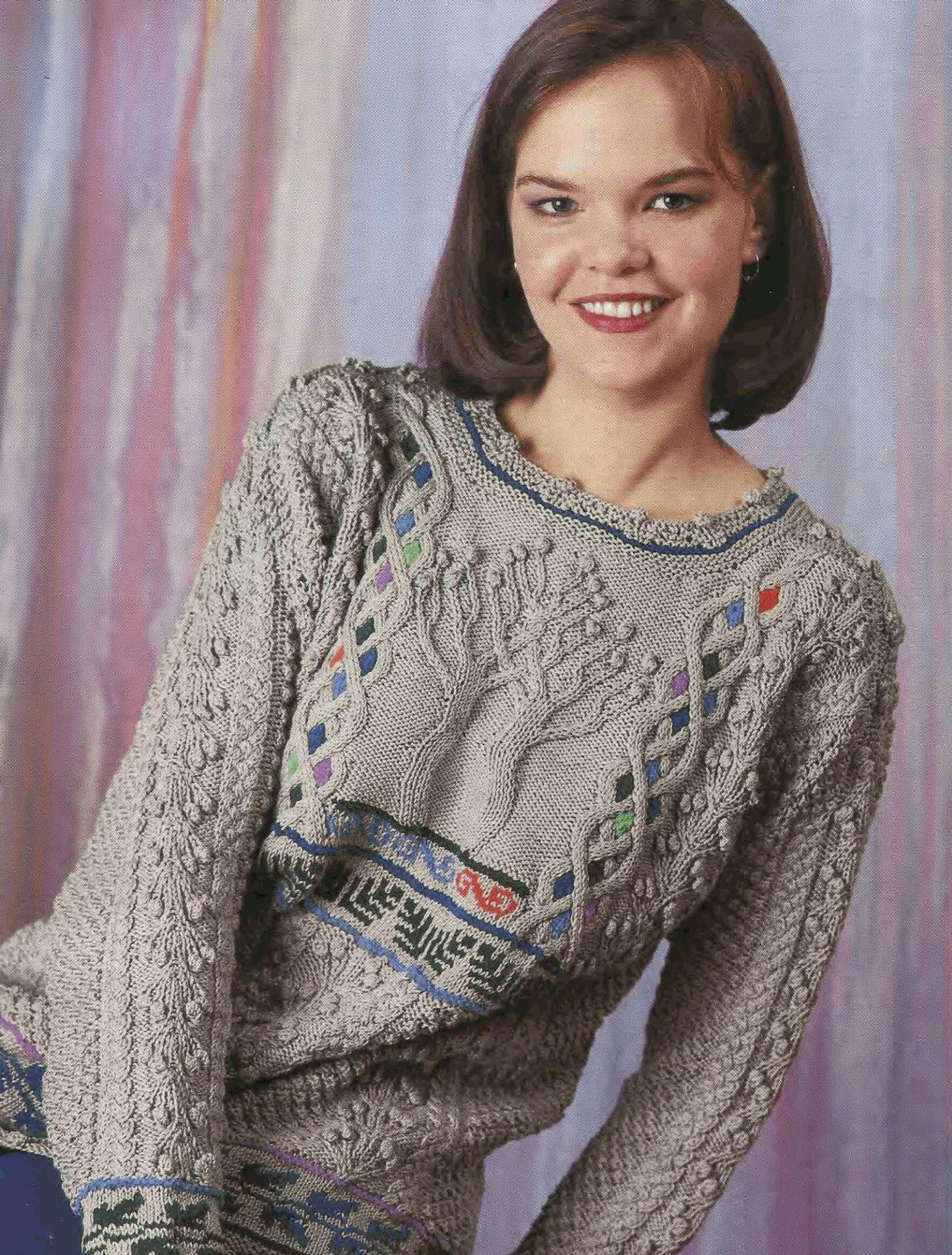

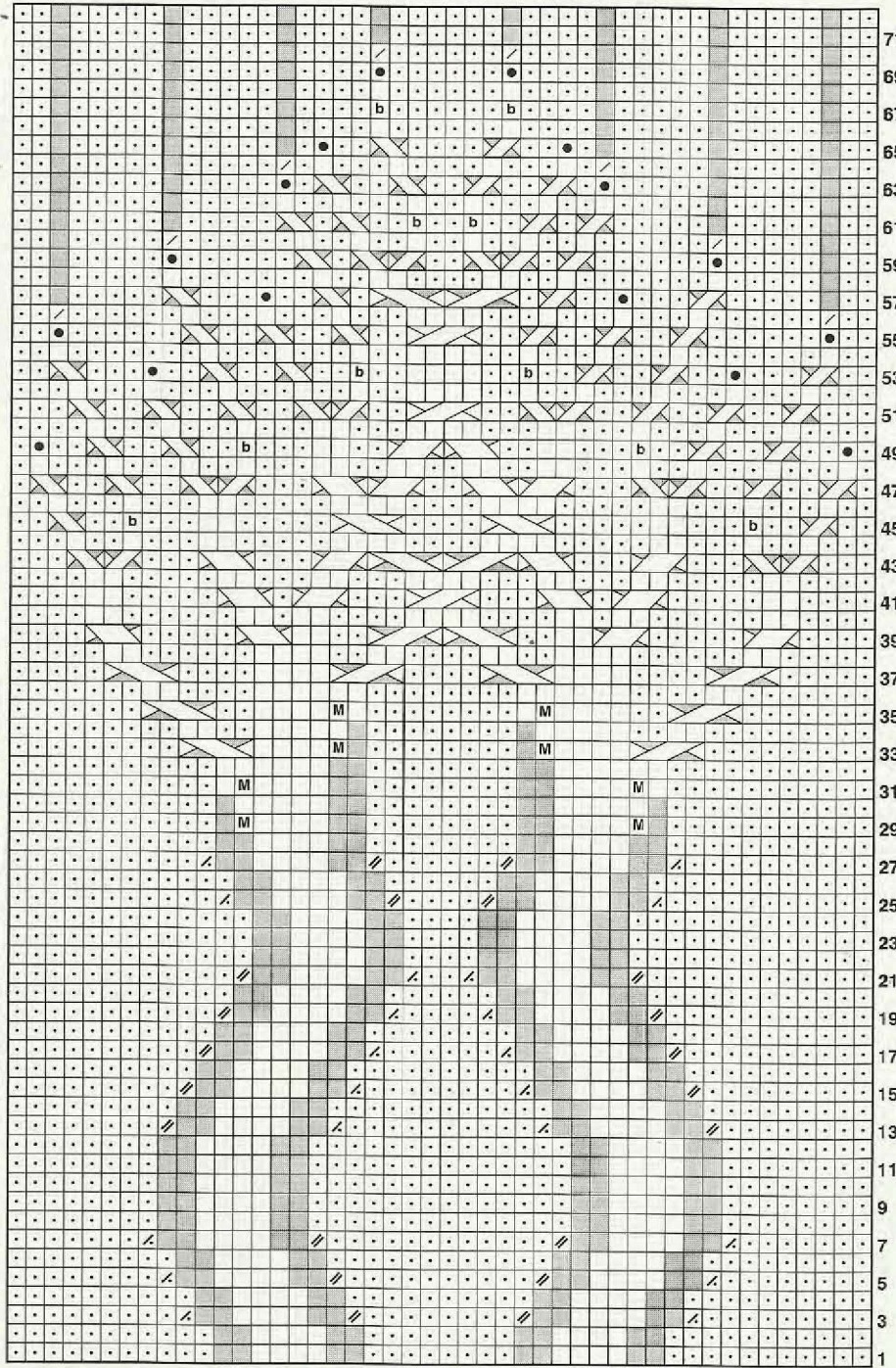

Leaves

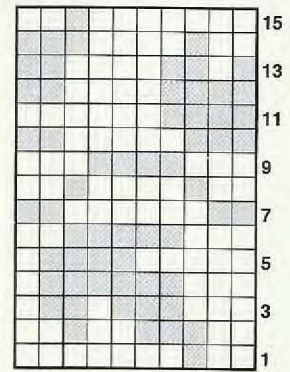

Color Cable

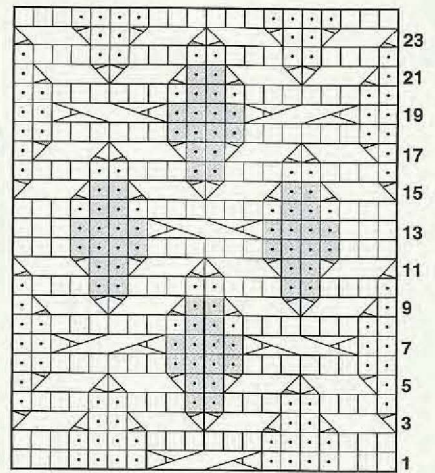

Purl marked sts of cable centers for plain version; knit colored cable centers with CC for stained glass version.

Note: Use intarsia to add CC into the cable nooks where desired. When the groups of 3 knit sts (forming the raised cable) are moved outward, use a CC to knit the purl st that moves into the empty space. To prevent bits of color from showing on the outer edge of the raised cables, purl CC sts with MC on the WS row just before those sts are moved back out to become purl sts again (or moved over to become a different CC in a different nook).

- CC1, CC2, CC3, CC4, or CC5
- bobble: k into back, front, back of st—3 sts, turn and p3, turn and k3, turn and p3, turn and sl1, k2tog, pssso
- k on RS; p on WS
- p on RS; k on WS
- p in front and back of st
- p2tog
- M1
- k1tbl
- no stitch

- 3/3RC: sl 3 sts onto cn and hold in back, k3, k3 from cn
- 3/3LC: sl 3 sts onto cn and hold in front, k3, k3 from cn
- 2/2RC: sl 2 sts onto cn and hold in back, k2, k2 from cn
- 2/2LC: sl 2 sts onto cn and hold in front, k2, k2 from cn
- 1/1RC: sl 1 st onto cn and hold in back, k1, k1 from cn
- 1/1LC: sl 1 st onto cn and hold in front, k1, k1 from cn
- 3/1RCP: sl 1 st onto cn and hold in back, k3, p1 from cn
- 3/1LCP: sl 3 sts onto cn and hold in front, p1, k3 from cn

- 2/2RCP: sl 2 sts onto cn and hold in back, k2, p2 from cn
- 2/2LCP: sl 2 sts onto cn and hold in front, p2, k2 from cn
- 2/1RCP: sl 1 st onto cn and hold in back, k2, p1 from cn
- 2/1LCP: sl 2 sts onto cn and hold in front, p1, k2 from cn
- 1/1RCP (RS and WS): sl 1 st onto cn and hold in back, k2, p1 from cn
- 1/1LCP (RS and WS): sl 1 st onto cn and hold in front, p1, k1 from cn

Cherries

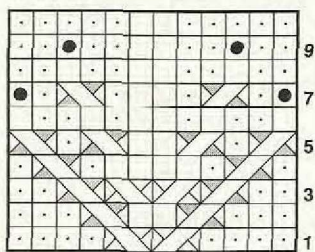

Note: Cable crosses are made on both RS and WS rows. Remember to read chart from left to right on even-numbered (WS) rows.

Braid

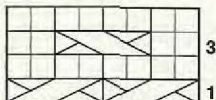

Spiral

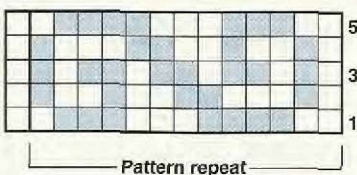

Pine Needles

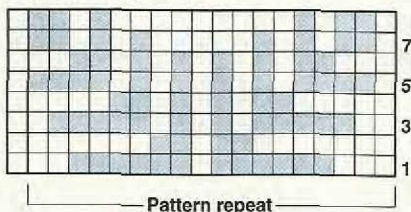

Invisible Cast-On

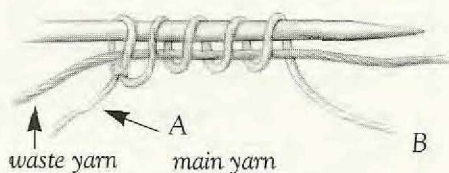

Make a slip knot (A) and place it on the left needle. Pull the waste yarn from left to right through the loop and lay in underneath the needle. Hold the slip knot and waste yarn in place with the left hand. Wind the main yarn round the needle plus waste yarn, over and away from you, under and towards you. As you get near end B, pull a little more through. Make as many turns as you need stitches. Do not pull the waste yarn out until you are ready to pick up the loops to knit them.

MC, dec 1 st at each edge of center panel. Work 1 row. Next row (RS) begin Tree chart on center 38 sts. Cont in all patt as established to end of Tree chart. Piece should measure 20½ (22, 23½, 23½)" (52.5 [56, 60, 60] cm) from beg. **Shape neck:** Work across 60 (68, 76, 84) sts in patt. Place center 28 sts on holder for front neck. Join new yarn and work in patt across rem 60 (68, 76, 84) sts. Working both sides separately, dec 1 st at neck edge every row 12 times and then every other row 7 times—41 (49, 57, 65) sts rem each side. Cont in patt until piece measures same length as back to shoulder. Place rem sts on holders.

• **Shoulder Strap:** The following instructions apply to both the left and right shoulder straps; the only difference is which piece of the sweater faces you as you work. Place the shoulder sts of the front and back of one side of the sweater onto needles with the points toward the neck edge. With the right sides of the sweater facing you and using the invisible method (shown at left), CO 16 sts onto the left needle.

Row 1: (RS) P2, work Row 1 of Cherries over 12 sts, p1, p2tog (last st CO and edge shoulder st).

Row 2: (WS) With yarn in front, sl next shoulder st from right needle to left needle, k2tog (the slipped st and first strap st), k1, cont in Cherries patt across 12 sts, k1, k2tog (last strap st with first shoulder st).

Row 3: With yarn in back, sl next shoulder st onto left needle, p2tog (edge shoulder st with first strap st), p1, and cont as in Row 1.

Cont working Cherries patt and joining strap to the front and back at the beg and end of each row until all of the shoulder sts are used up, ending with a RS row. Rep for the other shoulder.

• Sleeves:

Row 1: With MC, RS facing, and cont from 16 shoulder strap sts, pick up and knit 55 (59, 67, 71) sts evenly spaced around 8 (8½, 9¾, 10½)" (20.5 [21.5, 25, 26.5] cm) of armhole.

Row 2: Purl back over sts picked up, work strap sts in established patt, then pick up and purl 55 (59, 67, 71) sts evenly spaced around rem 8 (8½, 9¾, 10½)" (20.5 [21.5, 25, 26.5] cm) of armhole—126 (134, 150, 158) sts total.

Row 3: Work 1 edge st, work Bramble over

44 (48, 56, 60) sts, p2, work Braid over 8 sts, p2, work Cherries over 12 sts, p2, work Braid over 8 sts, p2, work Bramble over 44 (48, 56, 60) sts, work 1 edge st.

Cont in patt as established, dec 4 sts every 8 (8, 6, 6) rows as follows: (Note: Because of the structure of the Bramble, it is easiest to dec an entire patt rep on one side of the sleeve and then to do the same on the other side. The edges end up a little uneven, but when the underarm seam is sewn and the sleeve is blocked, the unevenness disappears.)

Row 1: In the edge rep of the Bramble patt, p3tog as usual but just knit the other st without inc to 3 sts—2 sts dec'd.

Rows 2, 4, 6, and 8: Purl.

Row 3: P2tog (the rem 2 sts from Row 1).

Row 5: Incorporate the last st into the adjacent patt rep by either p4tog or p1, k1, p1 into 2 sts tog.

Row 7: For the two smallest sizes, work as usual in established patt. For the two largest sizes, this row will be the first row of a dec at the other edge of the sleeve.

Alternate sides, dec 4 sts in this manner every 8 (8, 6, 6) rows until 66 (74, 70, 78) sts rem and piece measures 15½ (16, 16½, 17)" (39.5 [40.5, 42, 43] cm) from beg.

Cuff: With smaller needles and CC, knit 1 row, dec 16 (24, 20, 28) sts evenly spaced—50 sts rem. Knit 1 row—1 garter st ridge. With MC, work 2 rows St st. Work Leaves chart. With MC, purl 1 row. With a CC, knit 2 rows. With MC, knit 2 rows, inc 1 st at end of last row—51 sts. Beg with Row 7, work Bobble Border in reverse order through Row 3, purling all WS rows. BO as follows: BO 5 sts in purl, leaving the last st on right needle, *(k1, p1, k1, p1) in next st, [turn, k4] 3 times, turn and lift 2nd, 3rd, and 4th sts one at a time over 1st st and off left needle, k1 (the rem st of the group just worked), pass st on right needle over rem st of bobble, BO 9 sts in purl; rep from *, end last rep BO 5.

• **Finishing:** With yarn threaded on a tapestry needle, sew sleeve and side seams.

Neckband: With MC, smaller dpn, and beg at back edge of left shoulder strap, knit 16 sts from left shoulder strap, pick up and knit 15 sts along left front neck edge, k28 sts from front neck holder, pick up and knit 15 sts along right front neck, k16 sts from right shoulder strap, and k52 sts from back neck holder—142 sts. Place in and join. Purl 1 rnd. Knit 1 rnd, dec 12 sts evenly spaced

across center front 40 sts (to prevent tree pattern from distorting)—130 sts rem. Purl 1 rnd, knit 1 rnd, purl 1 rnd. With a CC, work 2 rnds (1 ridge) garter st. With MC, knit 1 rnd. Beg with Row 7, work Bobble Border in reverse order, knitting all even-numbered rnds. BO as follows: BO 4 sts in purl, leaving the last st on right needle, *(k1, p1, k1, p1) in next st, [turn, k4] 3 times, turn and lift 2nd, 3rd, and 4th sts one

at a time over 1st st and off left needle, k1 (the rem st of the group just worked), pass st on right needle over rem st of bobble, BO 9 sts in purl; rep from *, end last rep BO 5. Weave in loose ends. Block. ∞

Sarah Swett lives in Moscow, Idaho, where she spins, knits, and weaves. She comes up with many of her more interesting ideas while washing dishes, and loves to put her notions out in the world, then watch what people do with them.

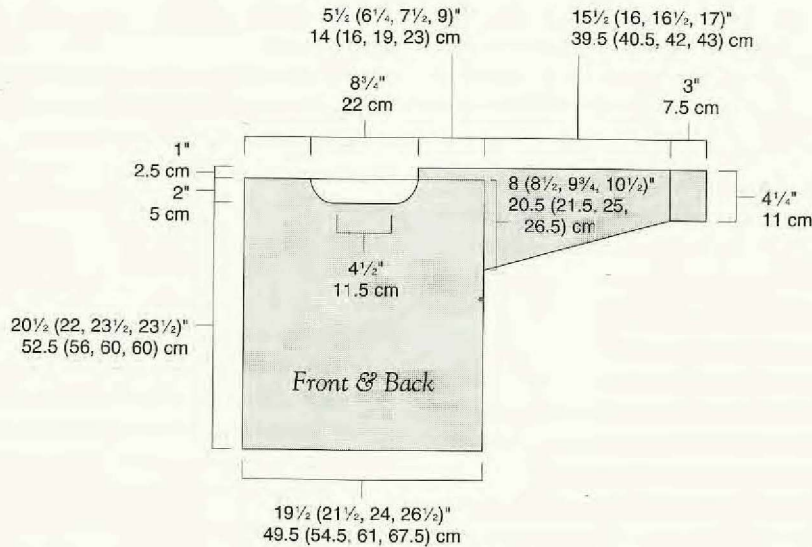

Nancie Knits Videos

by Nancie M. Wiseman

Newest Video

Three Techniques for More Colorful Knitting

Slipped Stitches, Intarsia and Fair Isle
\$35.

Continental Knitting

All the information needed to learn this faster knitting technique, with lots of closeups.

\$25.

Best Selling Video

Basic Sock Video

Information and pattern for creating simple socks.

\$20.

Entrelac and Seamless Bobbinless

Argyle Socks

Includes patterns for these exciting techniques.

\$25.

Add \$4.00 shipping and handling for each video.

Call or Write:

Nancie Knits

3214 Riverside Blvd. Sacramento, CA 95818

email: NancieKnits@prodigy.com

(916) 443-6238

ORDER LINE: 800 867-2074

Visa or MC

California residents add 7.75% tax

FLOUCAULT HANDKNITS

The Better Sweater Kit

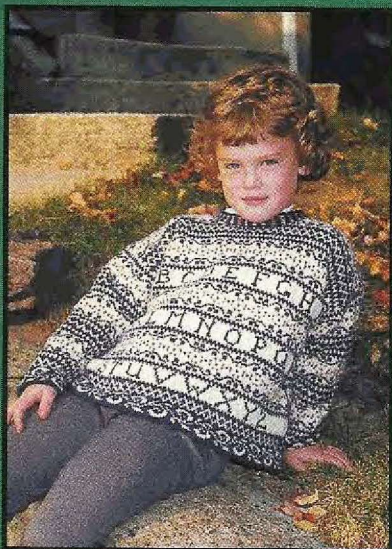

Do you love the feel of high quality yarn at your fingertips?
Do you enjoy the sense of accomplishment and pride that comes with wearing - or giving - a unique creation?
Are you comfortable hearing compliments?

Bring your ability and passion to the next level with a kit from Floucault Handknits.

Ask about our gift certificates and custom design service.

Call (781) 322-9228 for a color catalogue, \$5 (refundable with first order) or write: Floucault Handknits

16 Hazelwood St. Malden, MA 02148



"A Norski Sweater and Cap for Toddlers" (Sizes 1, 2, & 3)

Cottage Creations has a new pattern designed to guide the knitter through a Norwegian knitting experience, but in a small dose! This cardigan is knit in the round in sport weight, then finished in traditional Norsk fashion! A departure from Cottage Creations, because it isn't seamless!

Pattern is \$6.00 ppd.

Visa/Mastercard

515-324-1280

Or send LSASE for brochure.

Cottage Creations
At the Farm on Deer Creek
Carpenter, IA 50426-0070

We are pleased to announce that we are the new
USA distributor for Swallow Casein Knitting Needles.

These smooth, comfortable needles are made in Australia
from casein, a natural milk protein.
They come in 9", 12" and 14" lengths in single points and 9" double points (5 per set).

Crystal Palace Yarns

3006 San Pablo Ave., Berkeley, CA 94702
510-548-9988 fax: 510-548-3453

Descriptive brochure on request,
or see our Web page: <http://www.straw.com/cpy>
Dealer inquiries welcome.

KNITS FOR KIDS...
'Bliss'ful sweaters kids love to wear.

Debbie Bliss is known for her sweater designs for children. Most are knit in sport, DK, or worsted weight yarns for faster knitting, and the styles are contemporary in shape, color, and patterning. Free shipping with an order of two or more books. This special is good through April 30, 1998.



For Age 0-6 Years

Bright Knits for Kids \$19.95
Classic Knits for Kids \$13.95
Kid's Country Knits \$18.95
**Kid's Knits: Heads, Hands,
& Toes** \$18.95

To Age 10

Great Knits for Kids \$22.95

For Age 0-3 Years

Baby Knits \$17.00
New Baby Knits \$16.95
Nursery Knits \$17.95

For All Ages

Teddy Bear Knits \$18.95

CALL

1-800-468-0035

YARN BARN

930 Massachusetts
Lawrence, KS 66044



Not Just for Special Occasions ...



Brittany
fine wood knitting needles & crochet hooks

P.O. Box 130
Dept. IK
Elk, CA 95432

Phone Toll-Free
1-888-488-9669

Green Mountain MADNESS

Judith Durant

AFTER A VERY HECTIC WEEK of business and pleasure in the most unpleasant “August-in-New-York-City” mugginess, I was delighted to get in a car and head north to the Green Mountains of Vermont, home to Cheryl Potter’s Cherry Tree Hill Farm. I’d met Cheryl at Stitches East in 1996 and was impressed with both the woman and her work.

Cheryl creates luscious handpainted yarns in a variety of fibers. With names such as Quarry Hill, Champlain Sunset, and Green Mountain Madness, the yarns are positively irresistible in skein; after knitting with some, I’ve found them to be just as scrumptious in fabric. Cheryl draws color inspiration from her view, a 180° panorama of the Winooski Valley. Close your eyes and imagine Vermont sugar maples in October and you’ll have a picture of the rust, orange, fuchsia, and fading purple that is her Fall Foliage colorway.

So how exactly does someone end up painting yarn in Vermont? Traveling in Tibet in 1985, Cheryl was struck by the simple beauty of the local carpets. She watched dirty white wool become works of art and was fascinated to see children at work in their creation. If they could do it, so could she. Then in her early twenties, Cheryl went to Tucson, Arizona to pursue her MFA degree. There she saw the fiber craft of the Navajos, and it reminded her of what she’d seen in Tibet. Navajo yarns and the Southwest had a

huge influence on her work. She tried working with sheep, cleaning and spinning wool, but it was her love of working with color that stuck.

Fate landed her in a wonderful farmhouse at Cherry Tree Hill, and from 1989 to 1993 she ran the house as a bed and breakfast inn. She was also selling sweaters and yarn from the house. When she finally realized she was lodging more fiber than people and liking it, she stopped renting rooms. In 1994 she attended several fiber shows and was delighted to meet other serious fiber people; this gave her the courage to really try and make a go of a life based on yarn.



PHOTOGRAPHY BY RICK MASTELLI

Left: A “Tropical Storm” of mohair, wool, rayon, and cotton.

Cheryl likes to dry her painted yarn in the sunshine.



Cheryl applies dye to white yarn placed in a steamer tray.

TRADE SECRETS

Cheryl is quick to share her “secrets” and her opinion that the process of handpainting yarn is really quite simple. She buys plain white yarns in a range of fibers—mohair, wool, rayon, cotton, and silk; worsted, bouclé, and chenille. Because her premier mission is to make “designer” yarns accessible to everyone, she buys from many different sources and looks for good bargains on quality yarns, buying huge closeouts whenever possible.

Her methods are, indeed, quite simple. Using ProChem dyes—MX Fiber-Reactive for plant fibers and Washfast Acid for animal fibers—mixed to colors of her liking and siphoned into plastic bottles such as those used by hair colorists, Cheryl applies this “paint” to her “canvas” made of white yarn placed in steamer trays. Because she starts with dry fiber, Cheryl adds Synthrapol, a wetting agent, to her dyes to ensure saturation. The most exciting part of painting for Cheryl is when she stops one color and begins the next. At this juncture she encourages the colors to blend, which results in random bits of striking and sometimes unexpected shades—through blending, four colors can become ten or twelve.

Once she’s painted the yarn, Cheryl puts a lid on the tray and moves it to a gas stove where the yarn sits in steam for twenty minutes while the dye sets—ten minutes of steam, open the tray and flip the yarn over, ten more minutes of steam. During the steaming process, the dyes have a tendency to run; if there’s too much dye,

the colors all run together and become a brown blob. So here’s Cheryl’s big secret: the trick to successful handpainted yarn is learning to use the least amount of dye possible for full saturation. That’s it.

Weather permitting, Cheryl moves her skeins outdoors to dry. Although probably impossible—she produces 400 pounds of painted yarn each month, all by herself—I like to imagine Cheryl hanging her skeins on a rack strategically placed in the sun, and then strategically placing herself on an inflated raft and floating around in the swimming pool while the yarn dries.

Once the yarn is dry, it’s ready for use, right? Wrong. There is one more step in Cheryl’s process, and she calls this making the yarn “retail ready”. Yarn painted in blotches and stripes looks just like that: blotchy and stripey. And apparently these are not qualities that sell. So, using modified weaving equipment, Cheryl rewinds her random skeins into one- or one-and-a-half-yard hanks. This rewinding results in balanced-looking hanks, ones in which the many colors are more or less evenly distributed throughout; these hanks more accurately represent what a knitted fabric will look like. Now here’s something Cheryl finds really cool. To her, a beautiful skein of yarn is the end product from Cherry Tree Hill Farm. But to the buyer, it’s the beginning—raw material just waiting to become something else. Living art. What a concept.

ART HAPPENS

Cheryl likes to experiment with colors and fibers, and she’s had some happy accidents. One day she inadvertently left a pot of dye on the stove when she went out to do errands. When she returned, the dye



A happy accident resulted in a line of “scorch-dyed” yarns.

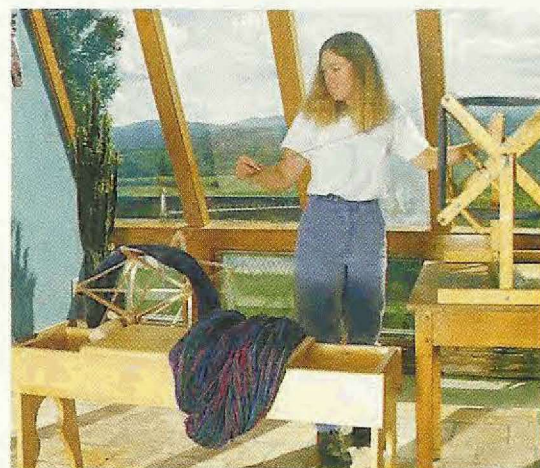

When the painted yarn is dry, Cheryl rewinds it into “retail-ready” hanks.



had burned to the bottom of the pot. She turned the gas off and filled the pot with water, hoping to loosen some of the caked-on muck. And loosen it she did: before her eyes the dye colors began to separate and float. Seizing the opportunity, Cheryl threw a skein of yarn into the pot and watched it take up the dye at different rates. Voilà, her line of “scorch-dyed” yarns was born.

Cheryl is close to making a living with her yarn. She has a small cult following to whom she sends a bimonthly newsletter. To receive the newsletter, send an SASE to Cherry Tree Hill Farm, PO Box 254, East Montpelier, VT 05651. She drives and flies around the country doing trade shows and teaching workshops, the latest of which she calls “Reinventing timeless treasures: Jazzing up tried and true patterns with handpainted yarn.” This idea is epitomized on the following pages. Using a traditional gansey pattern from *Knitting Ganseys* by Beth Brown-Reinsel (Interweave Press, 1993), Cheryl has reinvented a classic with Green Mountain Madness. ☞



MUTED MUSICIAN GANSEY

BETH BROWN-REINSEL

*Traditional gansey
patterning*

Worked in the round

FINISHED SIZE 34 (38, 42, 46, 50, 54)" (86.5 [96.5, 106.5, 117, 127, 137] cm) bust/chest circumference. Sweater shown measures 42" (106.5 cm).

YARN Cherry Tree Hill Green Mountain Mohair (85% wool, 15% mohair; 1140 yd/24 oz [1042 m/680 g]): green mountain madness, 24 (24, 24, 28, 28, 32) oz.

NEEDLES Body and Sleeves—Size 9 (5.5 mm): 24" (60 cm) circular (cir) and double-pointed (dpn); Ribbing—Size 7 (4.5 mm): 24" (60 cm) cir and dpn. Adjust needle sizes if necessary to obtain the correct gauge.

NOTIONS Markers (m); five stitch holders; tapestry needle.

GAUGE 16 sts and 24 rnds = 4" (10 cm) in St st.

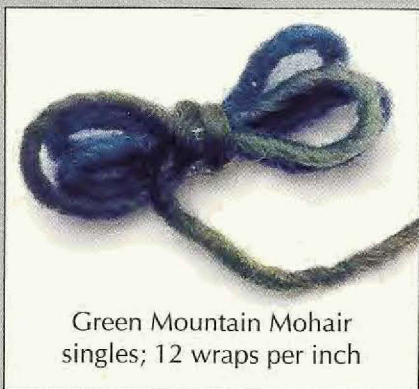

Green Mountain Mohair singles; 12 wraps per inch

THIS PULLOVER features traditional nineteenth-century gansey, or guernsey, construction: rich knit/purl patterning, dropped shoulders, garter stitch "seam" stitches at each side, and underarm gussets that allow the wearer additional freedom of movement. The stitches for this gansey are cast on with a double thickness of yarn for durability. The body is worked in one piece in the round from the lower ribbing to the armholes (including half of the underarm gussets). Then the front and back are worked back and forth separately to the shoulders. Shoulder stitches are bound off together for the shoulder seams and then sleeve stitches are picked up around the armholes, including the gusset stitches, and the sleeves are worked in the round down to the cuffs.

This pattern is one of six offered by Beth Brown-Reinsel in her book *Knitting Ganseys* (Interweave Press, 1993).

•**Body:** With smaller cir needles, strand of yarn, CO 120 (136, 148, 164, 180, 192) sts. Place m and join, being careful not to twist sts. Drop the extra strand of yarn. Work k2, p2 ribbing until piece measures 3" (7.5 cm) from beg. Change to larger cir needle and St st, inc 16 (16, 20, 20, 20, 24) sts evenly spaced on first rnd—136 (152, 168, 184, 200, 216) sts. On next rnd, mark seam sts as follows: *K67 (75, 83, 91, 99, 107), pm, p1 (seam st), pm; rep from *. Cont in St st, working the seam sts in Garter st (alternating knit and purl), until piece measures 4 (6 $\frac{1}{4}$, 7, 7 $\frac{1}{4}$, 7 $\frac{1}{2}$, 7 $\frac{3}{4}$)" (10 [16, 18, 18.5, 19, 19.5] cm) from beg. Beg patt as follows: *Work seam st, k2 (2, 4, 4, 4, 4), work Row 1 of Body chart, beg and ending as indicated for your size, k2 (2, 4, 4, 4, 4); rep from *. Cont in patt until piece measures 10 (12 $\frac{1}{4}$, 12 $\frac{1}{2}$, 12 $\frac{1}{2}$, 12 $\frac{1}{2}$, 13)" (25.5 [31, 31.5, 31.5, 31.5, 33] cm) from beg. **Shape gussets:** Inc 1 st on each side of each seam st—4 sts inc'd. These inc'd sts become the new seam sts that outline the gussets. They are worked in the established Garter st seam patt. Inc 1 st just inside each of these new seam sts every third rnd 6 (6, 6, 6, 8, 8) times, working the new sts in St st—15 (15, 15, 15, 19, 19) gusset sts each side, including seam sts. Place seam and gusset sts on holders. Place 67 (75, 83, 91, 99, 107) front sts on holder. The front and back are worked

separately from this point on. **Back:** Cont working the back 67 (75, 83, 91, 99, 107) sts in established patt until piece measures 19 $\frac{1}{2}$ (21 $\frac{3}{4}$, 22 $\frac{1}{2}$, 22 $\frac{3}{4}$, 23 $\frac{3}{4}$, 24 $\frac{3}{4}$)" (50 [55.5, 57.5, 58, 60.5, 63] cm), or 1" (2.5 cm) less than desired length, ending with Row 1. Purl 1 row. Beg as indicated for your size, work Rows 1–5 of Yoke and Shoulder chart. Divide sts onto 3 holders—19 (21, 25, 27, 29, 32) sts for each shoulder and 29 (33, 33, 37, 41, 43) sts for back neck. **Front:** Place 67 (75, 83, 91, 99, 107) front sts on needle and work as for back until piece measures 18 $\frac{1}{2}$ (20 $\frac{3}{4}$, 21 $\frac{1}{2}$, 21 $\frac{1}{4}$, 22 $\frac{1}{4}$, 23 $\frac{1}{4}$)" (47.5 [53, 55, 54, 56.5, 59] cm), or 2 (2, 2, 2 $\frac{1}{2}$, 2 $\frac{1}{2}$, 2 $\frac{1}{2}$)" (5 [5, 5, 6.5, 6.5, 6.5] cm) less than desired total length. **Shape neck:** Cont in patt across 23 (25, 29, 31, 33, 36) sts, place 21 (25, 25, 29, 33, 35) sts on holder for front neck, join second ball of yarn and cont in patt across rem 23 (25, 29, 31, 33, 36) sts. Working each side separately in patt, dec 1 st at each neck edge every other row 4 times—19 (21, 25, 27, 29, 32) sts rem each side, and *at the same time*, when piece measures 19 $\frac{1}{2}$ (21 $\frac{3}{4}$, 22 $\frac{1}{2}$, 22 $\frac{3}{4}$, 23 $\frac{3}{4}$, 24 $\frac{3}{4}$)" (50 [55.5, 57.5, 58, 60.5, 63] cm), or 1" (2.5 cm) less than desired length, ending with Row 1, purl 1 row and then work Rows 1–5 of Yoke and Shoulder chart, beg as indicated for your size. **Join shoulders:** With RS tog, BO the shoulder sts tog (see Glossary, page 6).

•**Sleeves:** Place the gusset and seam sts onto a larger dpn. Join yarn and work across these sts. With another dpn, pick up and knit 67 (67, 71, 73, 73, 77) sts evenly spaced around the armhole—82 (82, 86, 88, 92, 96) sts total. Place m and join. Work 15 (15, 15, 15, 19, 19) gusset and seam sts, pm, k11 (11, 13, 14, 14, 16), work next 45 sts according to Sleeve chart (working from right to left to center st and then from left to right back to the beg), k11 (11, 13, 14, 14, 16). Cont in patt, shaping the gusset by dec 1 st just inside each seam st every third rnd 7 (7, 7, 7, 9, 9) times, working last dec k3tog—1 seam st rem; 68 (68, 72, 74, 74, 78) sts total. Cont in patt, working seam st in Garter st as before and dec 1 st each side of seam st (2 sts dec'd) every 4 (4, 5, 5, 5) rnds 17 (17, 17, 16, 14, 14) times—34 (34, 38, 42, 46, 50) sts rem. Work even until sleeve measures 16 (16 $\frac{3}{4}$, 17 $\frac{1}{4}$, 17 $\frac{1}{4}$, 17 $\frac{1}{4}$, 17 $\frac{1}{4}$)"



(40.5 [42.5, 43.5, 43.5, 43.5, 43.5] cm) from beg. Change to smaller dpn and dec 6 sts evenly spaced—28 (28, 32, 36, 40, 44) sts rem. **Cuff:** Work p2, k2 ribbing until cuff measures 3" (7.5 cm). BO loosely in ribbing.

• **Finishing: Neckband:** Place 21 (25, 25, 29, 33, 35) front sts and 29 (33, 33, 37, 41, 43) back sts on smaller dpn. Knit across

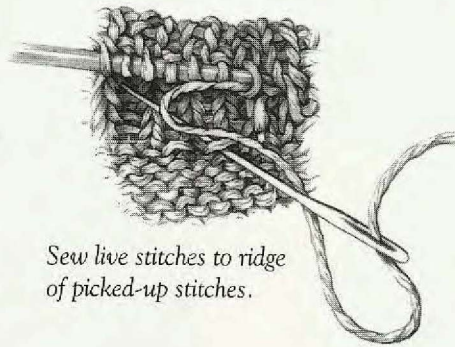

Sew live stitches to ridge of picked-up stitches.

the back sts, pick up and knit 9 (9, 9, 11, 11, 11) sts along left side neck, knit across the front neck sts, pick up and knit 9 (9, 9, 11, 11, 11) sts along right side neck—68 (76, 76, 88, 96, 100) sts total. Place m and join. Work k2, p2 ribbing until neckband measures 3" (7.5 cm). Fold band in half to the inside and sew the live sts to sts in the pick-up rnd. ∞

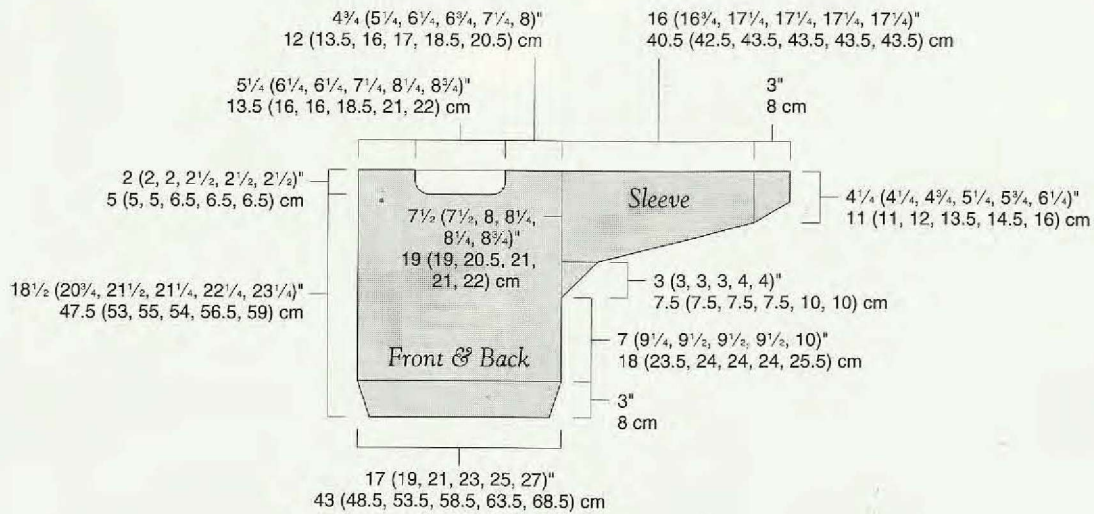

Sleeve

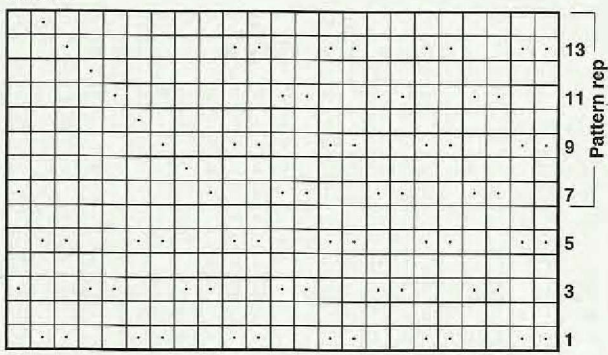

Yoke and Shoulder

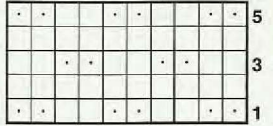

Body

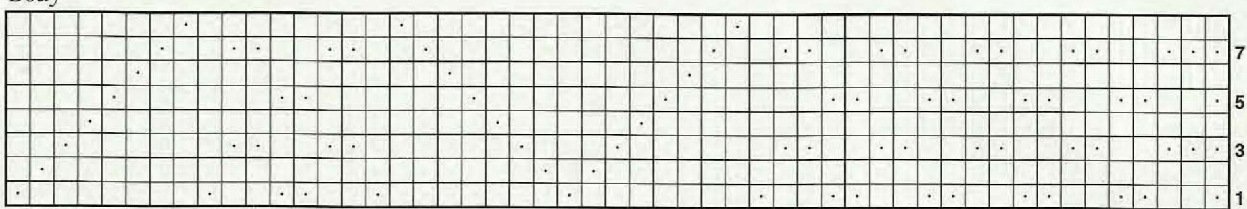

center st | Work all charts from right (beg as indicated) to left to center st and then from left to right back to where you began. | beg 34 | beg 38 | beg 42 | beg 46 | beg 50 | beg 54 | seam st

Work seam st for all sizes

The Wooden Cable Needle

Natural wood with
grooved center*
holds stitches
better than
aluminum
"hook" or "J"
needles...



Ask for
The Wooden Cable Needle at your local yarn shop,
or order direct from FibreTECH

Small (use with needle sizes 1-5)	\$3.00
Medium (use with needle sizes 5-8)	\$3.50
Large (use with needle sizes 8-up)	\$4.00
Set of all three - best value!*	\$10.00

NEW from FibreTECH!

The Tapestry Needle Case

Includes pockets for straight needles and a built-in zipper pouch for all
your knitting accessories (like The Wooden Cable Needle!)

Available in a variety of prints & colors
only \$24.95

*free shipping with purchase of set of three
CA residents include sales tax
MC, VISA, Discover, Personal Checks accepted
~ Wholesale inquires welcome ~

FibreTECH Specialty products for the fiber artist
248 Harbor Blvd Belmont CA 94002
phone 650 610 0555 fax 650 610 0557
email FibreT@aol.com

* patent pending



cherry tree hill yarn

handpainted yarns for the fiber fanatic in us all!
terrific textures unforgettable colors



cherry tree hill road,
east montpelier,
vermont 05651
(802) 229-0831

orders only:
1-800-739-7701

email:
cherryarn@aol.com

kits for handpainted muted musician's
gansey as seen in this issue: \$89 SML
\$115 XL available in 5 colorways

for current newsletter and brochure
send SASE or see us on the web:
www.cherryarn.com

colorcards \$4 each / specify colorway
wholesale accounts welcome!

CASCADING CABLES

DESIGNED BY JACQUELINE OLSEN

A graceful flow of cable, radiating
from the neck and widening
to form a flattering blouson
with smaller
cables at
wrists
and waist.

One size
fits most. Pure wool heathers—
amethyst, nutmeg, periwinkle,
rustic red, ebony or natural ivory.

Knitter's Kit, \$99 (\$6 S/H)

NY residents add sales tax.

ORDER TOLL-FREE 1-888-SEW-KNIT

Questions? Call 1-914-336-5322

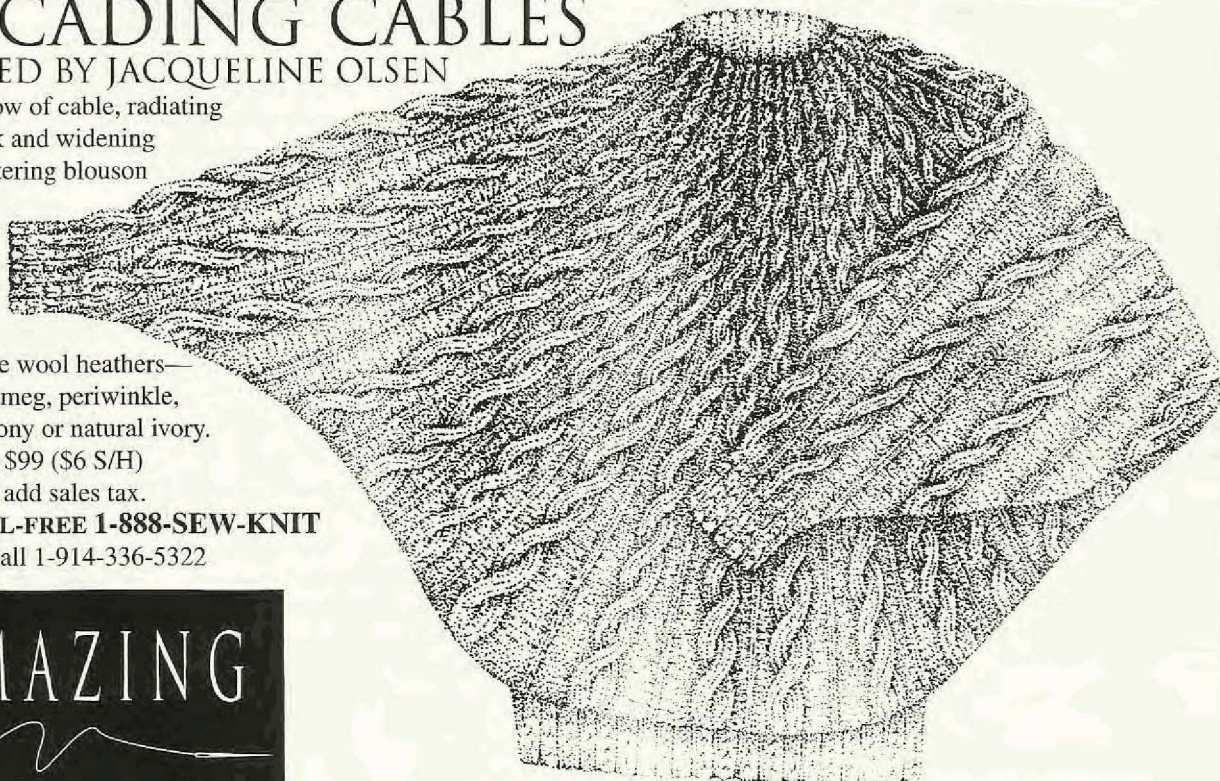

WRITE FOR OUR KNITTER'S FOLIO AMAZING THREADS
2010 ULSTER AVENUE, PO BOX 758, LAKE KATRINE, NY 12449

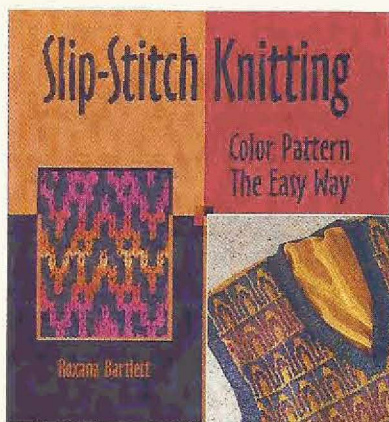

Slip-Stitch Knitting Color Pattern the Easy Way

Roxana Bartlett

"This book will please any knitter who enjoys combining colors and textures for novel effects." So says Barbara Walker, author of *Mosaic Knitting*, about Roxana Bartlett's exciting new book. With slip-stitch, also known as mosaic, you can create intricate multicolored patterns without having to carry two yarns. Bartlett's book provides all the basics, including how to read charts, make yarn and color choices, enhance designs with texture, and create your own original charts. Full-color photos of actual patterns demonstrate the author's techniques, and she provides instructions for thirteen original garments.

8½ × 9, paperbound, 96 pages, 36 color photos. #683—\$21.95

Available in March!

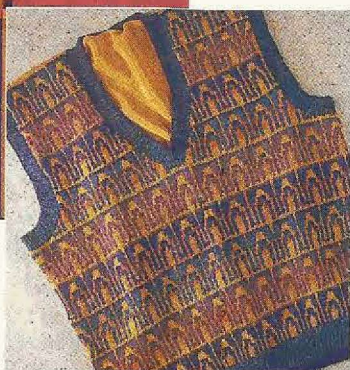

Available in April!

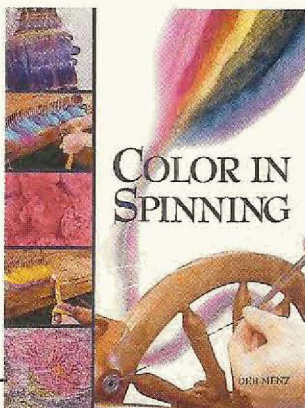

Color in Spinning

Deb Menz

Written expressly for the handspinner seeking new adventures in color, this comprehensive manual combines an accessible approach with technical savvy. Starting with the basics of the color/fiber relationship, Menz presents

step-by-step photographed demonstrations of immersion dyeing, painting rovings, blending colors and fibers with a drum carder, multicolor combing techniques, and spinning and plying multicolored preparations.

The novice will find a world of color to learn from while the expert will appreciate the author's insightful techniques.

8½ × 11, clothbound, 240 pages, 150 color photos. #690—\$39.95

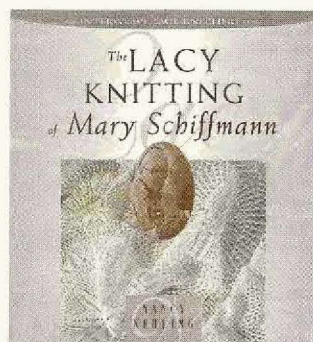

The Lacy Knitting of Mary Schiffmann

Nancy Nehring

You'll appreciate this book for its great projects and its great reading. A founding member of the Lacy Knitters guild, Mary Schiffmann was a tireless collector of lace patterns—and a delightful storyteller about her life and craft. Mary's friend

Nancy Nehring has lovingly collected Mary's legacy, patterns ranging from lace and edgings to an elaborate christening gown, and accounts of her life starting with her birth to missionaries in Japan and following her long life of lacy knitting in America.

8½ × 9, paperbound, 96 pages, charts and b&w photos. #776—\$17.95

Available in July!

Traditional Knitted Lace Shawls Revised Edition

Martha Waterman

Timeless and beautiful—those words describe the shawls presented in this revised edition of the classic text. Shapes include triangles, squares, circles, and half-circles, with openwork, textured stitches, and lace edgings to combine as you choose.

Everything you need to know to design and knit your own shawls is provided, while detailed corrected instructions for eight shawls are graphically rendered in all-new photography.

8½ × 9, paperbound, 112 pages, charts and b&w photos. #911—\$21.95

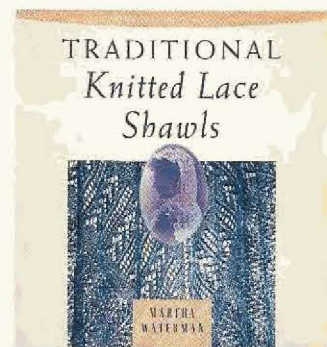

Find these books at your local craft source or call Interweave Books, Dept. IWPK, at 800-289-9276. Check our web site at <http://www.interweave.com>.

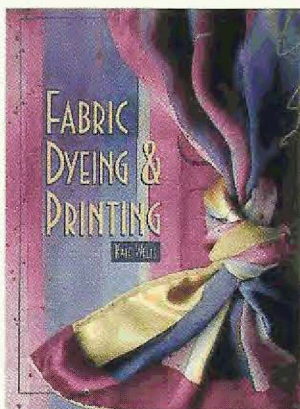

Fabric Dyeing and Printing

Kate Wells

If you could buy only one book on surface design, this would be it. The ultimate textile designer's bible, *Fabric Dyeing and Printing* combines step-by-step process photographs with over 100 full-color photographs of contemporary fabric. Throughout the book, careful attention is paid to the decorative effects that

can be created on fabric, from tie-dye through computer-generated imagery. Textural effects include a full chapter on devoré, plus crimping, flocking, and embossing. All in all, thirty key patterning techniques are presented, while twenty dye recipes are laid out in easy-reference cookbook style.

8 7/8 x 11 1/4, hardbound, 192 pages, 300 specially commissioned color photos. #724—\$39.95

Folk Mittens

Marcia Lewandowski

Welcome to the international mitten mall! Choose from Bohus Stickning mittens (three purples and off-white), geometrically patterned black and white Greek mittens, and multicolored Andean mittens patterned with animal motifs. All in all, 38 patterns include mittens from Austria, Kashmir, and colonial New England. Each pattern is presented with a full-color graph. Other technical coverage includes gauge, washing and felting, casting on, plaited edging, ribbed and unribbed cuffs, and a long section on thumbs, including three types of gores.

8 1/2 x 9, paperbound, 120 pages, 38 color charts and patterns. #694—\$18.95

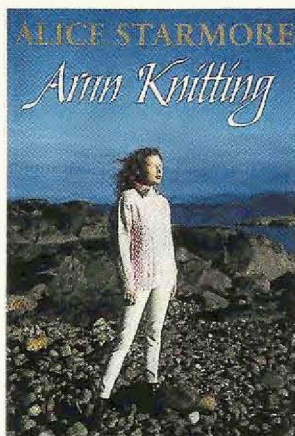
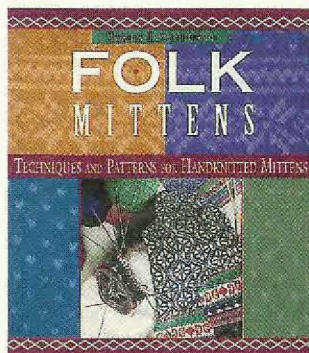

Aran Knitting

Alice Starmore

Packed with color and design, *Aran Knitting* presents a complete Alice Starmore workshop. Step-by-step instructions, photos, and drawings lead knitters through 60 charted patterns that progress from the basic concept of using a cable needle to the myriad variations of Aran technique. To develop creativity, Starmore then presents the design of a traditional Aran sweater. Full instructions and charted patterns for 14 original Alice Starmore designs include her own interpretations of Celtic knotwork. With the last-minute addition of previously-unpublished

historical information, and photos taken on location in the Aran Islands and County Clare, *Aran Knitting* is a real eye-opener on all the facets of this enduring style.

8 7/8 x 12, hardbound, 176 pages, color photos. #723—\$39.95

Enchanted Knitting Charted Motifs for Hand and Machine Knitting

Catherine Cartwright-Jones and Roy Jones

Authentic ancient motifs—from natural animals to mythological and imperial figures—are the basis for the charted designs in this new book. The third Interweave Press book from the design team of Catherine Cartwright-Jones and Roy Jones, *Enchanted Knitting* offers patterns based on the ancient Romanian beast-man Silvanus, figures in the Paleolithic caves of Europe, and tattoos from the famous Pazyryk woman of central Asia. Every design includes a discussion of the original motif in its historical context, plus knitting charts. There are also photos of completed garments incorporating the motifs.

8 1/2 x 10, paperbound, 96 pages, color photos and b&w charts and illustrations. #680—\$19.95

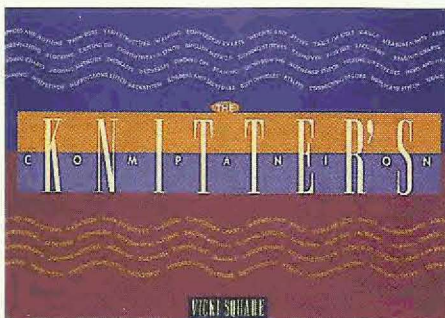
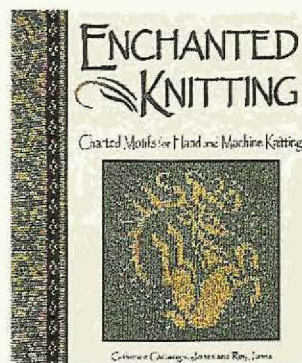

The Knitter's Companion

Vicki Square

Don't know how to do it? Forget how to do it? Need a new way to do it? Turn to *The Knitter's Companion*, the handy spiral-bound notebook that stays open while you knit. Measuring just 7 x 5 inches, the book fits in your totebag so you're never without clear illustrated diagrams for dozens of knitting techniques, including casting on, binding off, increasing, decreasing, correcting mistakes, making buttonholes, and sewing seams and hems. The book also offers invaluable tables of body measurements, yarn estimates, conversions, and more.

7 x 5, spiral-bound, 112 pages, b&w technique illustrations. #671—\$17.95

IN THE ROUND

Nancy L. MacKaben



From the Heart

I AM THE YOUNGEST of seven children and have been knitting since I was a child. On a whim I decided to knit afghans for my five sisters—Yvonne, Rowena, Carolyn Jean, Marilyn Sue, and Joyce Ann. After looking through several books without finding any patterns that caught my eye, I decided to design my own. Because I truly love my sisters, I designed a different heart motif for each afghan.

All five afghans are worked with two strands of worsted-weight yarn on size 17 (11 mm) needles. Each is bordered with ten rows of garter stitch at the top and bottom, and eight stitches of seed stitch along the sides.

I cast on a different number of stitches for each afghan based on the repeat of pattern stitches in the chart.

Nancy MacKaben works for a manufacturing company in Saint Louis, Missouri. During her lunch hour, she seeks out an empty office, takes off her shoes, and knits.



Photo taken in 1991
Here we're wearing T-shirts
I had printed with the 1943 photo.

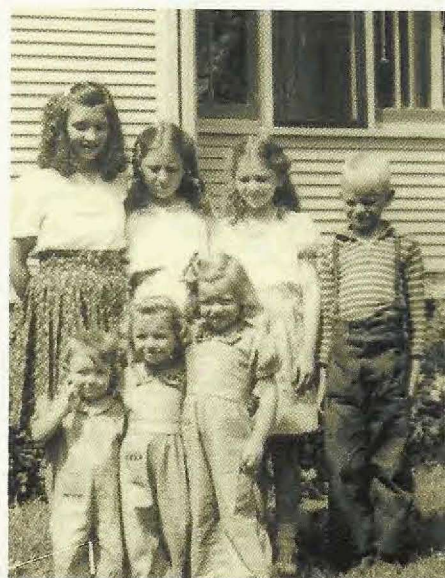
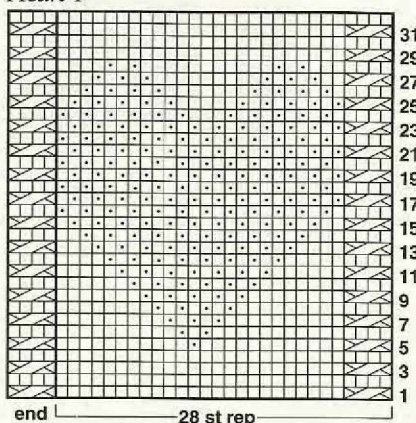
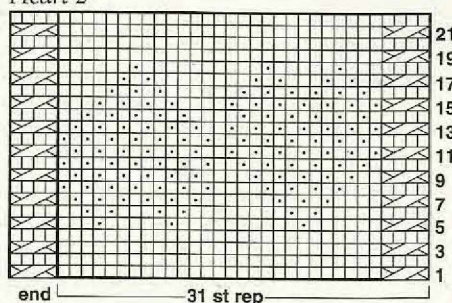

Photo taken in 1943
Top row, left to right: Yvonne, Rowena,
Joyce Ann, Ross
Bottom row, left to right: Myself, Marilyn
Sue, Carolyn Jean

Heart 1



Heart 2



Heart 3

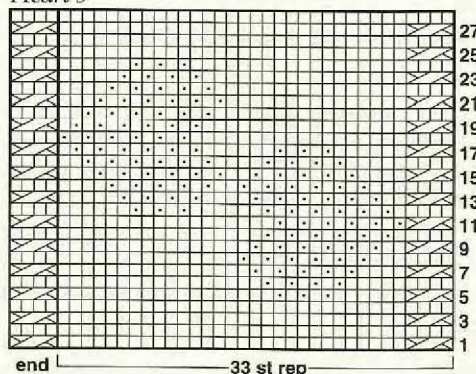

Heart 4

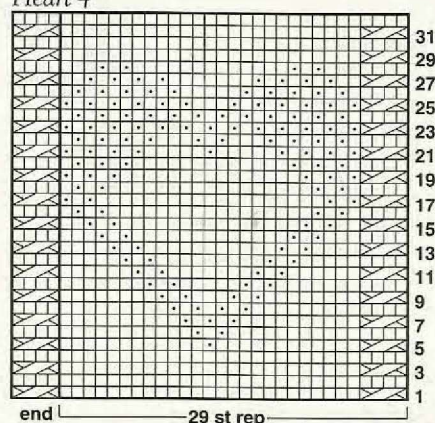

Heart 5

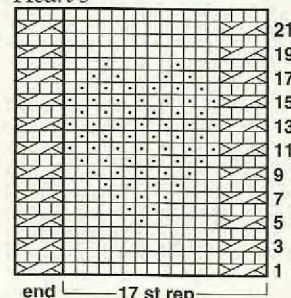

□ k on RS
p on WS

• p on RS
k on WS

⌘ 2/2 RC: sl 2 sts onto
cn and hold in back,
k2, k2 from cn



A STITCH ABOVE™

FINE YARNS * NEEDLEWORK * BUTTONS

Specializing in natural fiber yarns in all price ranges, including a large selection of washable wools and cottons.

ROWAN
JO SHARP
ALICE STARMORE
MISSONI - BERROCO

DALE OF NORWAY
CYNTHIA HELENE

ANNABEL FOX - MANDS

ADRIENNE VITTADINI

BROWN SHEEP - LOPI - STAHL

CLASSIC ELITE - TAHKI - LANG

WWW.ASTITCHABOVEKNITTING.COM

1-800-949-KNIT (5648)

190 WAYLAND AVE. PROVIDENCE, RI 02906

EVERYTHING YOU NEED FOR YOUR NEEDLEWORK PROJECTS

(and maybe some things you didn't even know you needed!)

We stock over 1,000 different yarns in a huge array of colors including:

- Vittadini
- Jaeger
- Classic Elite
- Tahki
- Colinette
- Prism
- Rowen
- Lang
- Lane Borgoesia
- Noro
- Plymouth
- Harrisville
- Annabelle Fox
- Dale of Norway
- Cynthia Helene
- Missoni
- Filatura
- Jo Sharp
- Berroco
- Brown Sheep
- Gedifra
- GGH
- Katia
- Maños
- Mountain Co.
- Muench
- Patons
- and lots more!

To Order: 1-800-306-7733

For a free newsletter/catalog send a card with name, address, phone and your interests.

PERSONAL THREADS
BOUTIQUE

Knitting • Weaving • Spinning • Needlepoint

8025 West Dodge Road • Omaha, Nebraska 68114 • Fax: 402-391-0039



Have some fun with Interweave Knits

Knitting's never a grind with *Interweave Knits*. Every project in the magazine is clearly illustrated to help you succeed.

Designs are inspirational, sometimes classic, sometimes contemporary, always exciting.

And you get a bonus with your subscription.

Twice a year, a special subscriber newsletter features projects

by staff and readers, plus

lots of your news about

knitting. To make sure

you receive *Interweave*

Knits and your

free newsletters,

subscribe or

renew today

(\$24, 1 year,

U.S.). Call

Dept. A-KB at

800-645-3675.



INTERWEAVE PRESS

201 East Fourth Street

Loveland, CO 80537-5655

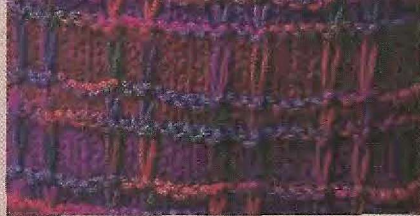

TARTAN PULLOVER

CHERYL OBERLE

Handpainted yarn

Slip-stitch patterning

FINISHED SIZE 43 (46, 49)" (109 [117, 124.5] cm) bust/chest circumference, blocked. Sweater shown measures 46" (117 cm).

YARN Brown Sheep Kaleidoscope (80% cotton, 20% wool; 107 yd [98 m]/50 g): anaheim (A), 7 (7, 7) skeins. Brown Sheep Cotton Fleece (80% cotton, 20% wool; 215 yd [197 m]/100 g): #850 berry (C), #202 rug red (E), 2 (2, 2) skeins each; #710 prosperous plum (B), #930 candy apple (D), 1 (1, 1) skein each.

NEEDLES Body and Sleeves—Size 5 (3.75 mm); Ribbing—Size 4 (3.5 mm). Adjust needle sizes if necessary to obtain the correct gauge.

NOTIONS Markers (m); nine stitch holders; tapestry needle.

GAUGE 22 sts and 37 rows = 4" (10 cm) in Tartan Slip-Stitch on larger needles, blocked; 22 sts and 28 rows = 4" (10 cm) in St st.



Brown Sheep Kaleidoscope
2-ply 3-strand, 4-ply;
11 wraps per inch

LOOSE-FITTING and cropped, this pullover combines handpainted and solid-colored yarn in a simple slip-stitch pattern to create a plaid. The two types of yarn are also united in two-color corrugated ribbings. The shoulder stitches are bound off together with the wrong sides of the knitting facing together to create a decorative ridge at the shoulders. The sleeves are also bound off into the armholes in the same way, which makes a flexible and easy sleeve seam.

Abbreviation

W2: K1, wrapping the yarn twice around needle.

Stitches

Corrugated Ribbing:

Rows 1 and 3: (RS) *K2 with B, p2 with A; rep from *, end k2 with B.

Rows 2 and 4: Purl the purls with B, knit the knits with A.

Rows 5–8: Rep Rows 1–4 using C instead of B.

Rows 9–12: Rep Rows 1–4 using D instead of B.

Rows 13–16: Rep Rows 1–4 using E instead of B.

Tartan Slip-Stitch: Note: Sl sts pwise.

Rows 1 and 2: With A, knit.

Row 3: With B, k1, sl 1, k2, sl 1, *k4, sl 1, k2, sl 1; rep from *, end k1.

Row 4: With B, p1, sl 1, p2, sl 1, *p4, sl 1, p2, sl 1; rep from *, end p1.

Row 5: With A, knit.

Row 6: With A, k1, W2, k2, W2, *k4, W2, k2, W2; rep from *, end k1.

Row 7: With C (and dropping extra loops off needle when slipping sts), k1, sl 1, k2, sl 1, *k4, sl 1, k2, sl 1; rep from *, end k1.

Rows 8, 10, and 12: With C, rep Row 4.

Rows 9 and 11: With C, rep Row 3.

Rows 13 and 14: Rep Rows 1 and 2.

Rows 15 and 16: With D, rep Rows 3 and 4.

Rows 17 and 18: Rep Rows 5 and 6.

Row 19: With E, rep Row 7.

Rows 20, 22, and 24: With E, rep Row 4.

Rows 21 and 23: With E, rep Row 3.

Rep Rows 1–24 for pattern.

•**Back:** With B and smaller needles, CO 120 (128, 136) sts. Join A and work Corrugated Ribbing, working 1 edge st in St st each end of needle (for seaming). Change to larger needles and Tartan Slip-Stitch

(cont to work St st edge sts) until piece measures 10 (10¼, 11½)" (25.5 [27.5, 29] cm) or desired length to armhole, ending with a WS row. **Shape armholes:** At the beg of the next 2 rows, place the first 8 sts on holders—104 (112, 120) sts rem. Cont in patt (with 1 edge st each side) until piece measures 19 (20, 21½)" (48.5 [51, 55] cm) from beg. Place 29 (31, 33) sts on each side on holders for shoulders. Place rem 46 (50, 54) sts on holder for back neck.

•**Front:** Work as for back to armholes. **Shape armholes and divide for V-neck:**

Cont in patt, work first 8 sts and place on a holder, work 52 (56, 60) sts, attach a second ball of yarn, work to end of row, turn, work first 8 sts and place on a holder. Working each side separately, work to end of row. **Shape V-neck:** Cont to work 1 edge st each side and dec 1 st at each neck edge on the next and every foll RS row 13 (14, 15) times total, then every 4th row 10 (11, 12) times—29 (31, 33) sts rem each shoulder. Cont in patt until piece measures same as back to shoulder. Place shoulder sts on holders.

•**Sleeves:** With B and smaller needles, CO 52 (52, 56) sts. Join A and work Corrugated Ribbing as for the back. Change to larger needles and Tartan Slip-Stitch, inc 2 (2, 6) sts evenly spaced in the first row—54 (54, 62) sts. Cont in patt, inc 1 st at each end of needle on the 5th row—56 (56, 64) sts. Then inc in this manner every foll 6th row 21 (23, 21) times—98 (102, 106) sts total. Work even until piece measures 18½ (20, 21½)" (47.5 [51, 55] cm) from beg. Place all sts on holder.

•**Finishing:** With WS tog, BO shoulder sts tog (see Glossary, page 6), working left side from shoulder to neck and right side from neck to shoulder. **Join sleeves to body:** With A, larger needle, and beg at underarm, k8 sts from one underarm holder, pick up and knit 82 (86, 90) sts around armhole, and k8 sts from other holder—98 (102, 106) sts total. With WS tog, and beg at underarm, BO sleeve sts tog with armhole sts as for the shoulder sts. **Neckband:** With A, smaller needles, and beg at the base of the V-neck, pick up and knit 62 (64, 66) sts along right front neck, knit 46 (50, 54) back neck sts, and pick up and knit 62 (64, 66) sts along left front neck—170 (178, 186) sts total. Turn and knit 1 row. Work Corrugated Ribbing with 3 rows



E, 2 rows D, 3 rows C, and 2 rows B. With B, BO all sts loosely in ribbing. With yarn threaded on a tapestry needle, sew side and sleeve seams. Lap right front of neckband over left front and stitch in place. Weave in all loose ends. Block. ∞

Cheryl Oberle of Denver, Colorado, learned to knit when she was four years old and now shares her passion for knitting by teaching workshops around the country. She is always searching for both unusual and simple ways to incorporate more color into her knitting.

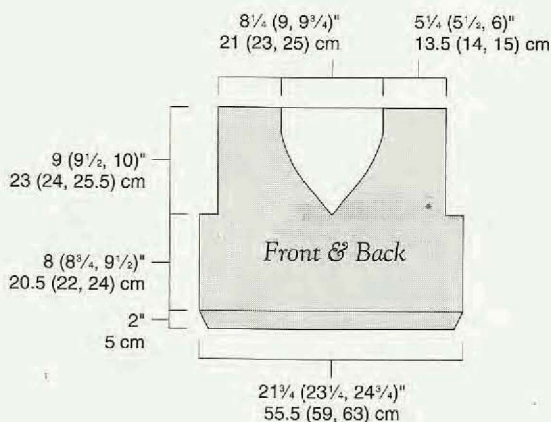
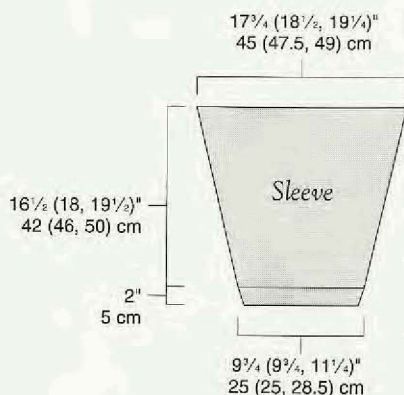

FREE Lion Brand Yarn Catalog



If you love yarn, don't miss this very special catalog! Filled with over 260 beautiful colors of yarn. Great gifts & kits to make for the holidays or just for fun!

For a copy of our catalog—just call, write or visit our website.

1-800-258-YARN(9276)
LION BRAND YARN COMPANY
 34 W. 15TH ST., NY, NY 10011-1K
<http://www.lionbrand.com>

Lacy Knit!

WITH MARY SCHIFFMANN!

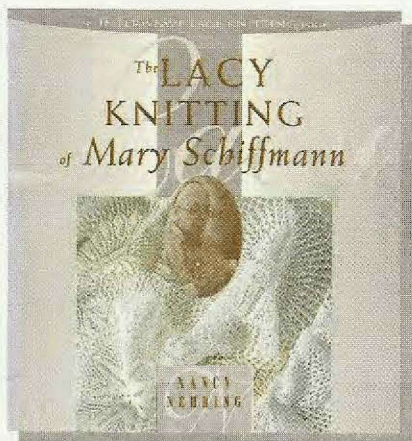

8 1/2 x 9, paperbound, 96 pages, charts and b&w photos. #776—\$17.95. Available in May.

Not only does *The Lacy Knitting of Mary Schiffmann* show you how to do a host of great projects, from simple edgings to an elaborate christening gown, it gives you tales from Mary Schiffmann herself. This accomplished craftswoman was also a delightful storyteller, and Nancy Nehring has lovingly collected examples of both Mary's achievements. Knit Cornwallis lace and read how Mary discovered the pattern. Knit Veil Nebula edging and read how Mary's love of astronomy influenced her designs. You're never without clear instructions and entertaining stories when you lacy knit with Mary.

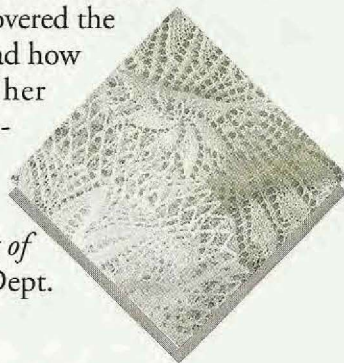

To order your copy of *The Lacy Knitting of Mary Schiffmann*, call **800-289-9276**, Dept. IWPK, today!

INTERWEAVE PRESS
 201 East Fourth Street Loveland, CO 80537-5655 <http://www.interweave.com>

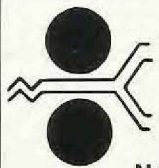

SUSAN'S FIBER SHOP

- carding
- spinning
- knitting

N 250 HWY. A
COLUMBUS, WI 53925
PH 920-MA-FIBER (623-4237)
Fax: (920) 623-0120

email: susanfiber@internetwis.com

Knitter's Supplies

- Yarn keeper bracelet, \$12.95
- Pageminders, \$7.50;
- Yarn Bras, \$3.50
- Nostepinne, \$10;
- Darning Egg, \$10
- Pair of sock stretchers, \$25
- Mitten stretchers \$20
- Knitting Gilleys \$10
- Mitten Book \$16
- Nalbinding Books I & II and needle – \$6 each

(shipping \$4 each item)

Books – Books – Books

Call For Listing

CLASSIC SWEATER KITS AND YARNS

Featuring Yarns from New England/Canada, Norway & Iceland, Authentic Guernsey Wool from England, Jo Sharp Yarns & Books, Rowan Kits & Yarns, Shetland and Aran Yarns

Domino Shell	\$115.00/129.00	Books	
Domino Jacket	\$250.00/260.00	Rowan Spring/Summer '98 Magazine	\$19.50
Garter Stitch Gymnastics Vest	\$290.00	Slip-Stitch Knitting	\$21.95
Mayan Socks (specify colourway)	\$50.00	The Lacy Knitting of	\$17.95
Parfait Sundress	\$45.00/53.00	Mary Schiffmann	
(specify colourway)		Folk Mittens	\$18.95

Visit us on the World Wide Web www.barkim.com or e-mail your order to barkimltd@aol.com

BARKIM LTD.

47 West Polk St., Suite 100-303, Chicago, IL 60605
Toll Free Orders! 888/548-2211 FAX 773/624-3380

VISA/MC

AMEX/DISC

★ PERSONAL SERVICE ★ EXPERT FINISHING ★

AYLIN'S WOOLGATHERER
1-800-775-WOOL

GREAT SELECTION OF EXQUISITE YARNS FROM ALL OVER THE WORLD. HUNDREDS OF BUTTONS.
AREA'S LARGEST COLLECTION OF PATTERN BOOKS.
ROSEWOOD & EBONY, ADDI, AND CLOVER NEEDLES.

Look us up on Internet: <http://www.aylins-wool.com>

AYLIN'S
7245 ARLINGTON BLVD., FALLS CHURCH, VA 22042 • (703) 573-1900
Ask for our brochures

INSTRUCTIONS INSTRUCTIONS

★ EXPERT FINISHING ★ PERSONAL SERVICE ★



Beth Brown-Reinsel

Knitting TRADITIONS

TWO SESSIONS OF KNITTING CAMP!

Knit sample sweaters of the Norwegian Lusekofte and the North Holland Swedish sweater, which Beth studied on her recent Scandinavian trip. Held in a Maryland mansion with great food! Come join us July 8–12 or Aug 20–23 for fun and friendship.

Catalog & 5 yarn cards:\$5

Imported Guernsey yarns
& Breed Specific Aran yarns! Kits, patterns, tools, books, newsletter

For more information, contact.

Knitting Traditions
PO Box 421-I * Delta, PA 17314
717-456-7950

e-mail: KnitTradit@aol.com
<http://members.aol.com/KnitTradit>



ANTIQUÉ LACE Finished size 34"-58" \$269

SAMUEL CHARIS KNITS

FINE SWEATERS IN KITS

UNIQUE DESIGNS, LUXURIOUS YARNS

Catalogue: 3 issues \$10/year—refundable with purchase
1-800-321-KNIT • 916-392-8213 • fax 916-392-8216 • email: knitkits@knitkits.com

Visit our website at: www.knitkits.com

372 Florin Road, Suite 312, Sacramento, CA 95831



PARFAIT SUNDRESS

LESLIEANN BESTOR

Easy slip-stitch patterning

Two colorways

FINISHED SIZE 23 (25, 27)" (58.5 [63.5, 68.5] cm) chest circumference. To fit size 4 (6, 8) years. Dresses shown fit 6 and 8 years.

YARN Classic Elite Provence (100% mercerized cotton; 256 yd [233 m]/125 g): **Colorway A:** #2625 rosa rugosa (MC), 2 (2, 3) skeins; #2617 heliotrope (CC1), #2694 China trade jade (CC2), #2657 DeNimes blue (CC3), #2696 helianthus gold (CC4), 1 (1, 1) skein each. **Colorway B:** #2617 heliotrope (MC), 2 (2, 3) skeins; #2657 DeNimes blue (CC1), #2696 helianthus gold (CC2), #2694 China trade jade (CC3), #2625 rosa rugosa (CC4), 1 (1, 1) skein each.

NEEDLES Size 6 (4 mm): 16" and 24" (40 and 60 cm) circular (cir). Adjust needle size if necessary to obtain the correct gauge.

NOTIONS Markers (m); three stitch holders; tapestry needle; size G/6 (4.25 mm) crochet hook.

GAUGE 19 sts and 28 rows = 4" (10 cm) in St st; 21 sts and 38 rows = 4" (10 cm) in Slip-Stitch pattern, after being machine washed and dried on cool cycles.

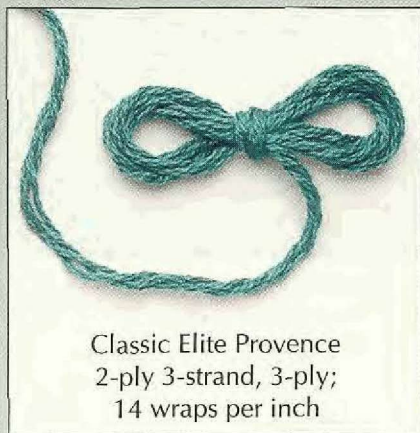

Classic Elite Provence
2-ply 3-strand, 3-ply;
14 wraps per inch

THIS PLAYFUL SUNDRESS, shown in two colorways, is worked in the round from the bottom to the armholes and then the back and front are worked separately to the shoulders. The bodice is worked in a slip-stitch pattern and the skirt is accented with raised welts made with a tuck stitch. The armholes and neck are edged with a row of single crochet.

Because the contrast colors require less than a ball of yarn each, this design is ideal for using up leftover bits of yarn. For more variation, combine yarns with different textures.

Stitches

Slip-Stitch Pattern: (multiple of 4 sts worked in the rnd) Note: Sl sts pwise unless otherwise noted.

Rnds 1–4: With CC1, *k3, sl 1; rep from *.

Rnd 5: With CC2, *k1, sl 1, k1, sl 1 kwise, reach tip of right needle under the 4 rows of CC1 horizontal bars behind st just slipped and draw up a loop on needle, then pss; rep from * (see figures below).

Rnds 6–8: With CC2, *k1, sl 1, k2; rep from *.

Rnd 9: With CC3, *k1, sl 1 kwise, reach tip of right needle under the 4 rows of CC2 horizontal bars behind the st just slipped and draw up a loop on needle, pss, k1, sl 1; rep from *.

Rnds 10–12: With CC3, *k3, sl 1; rep from *.

Rep Rnds 5–12 for pattern, changing colors every 4 rnds.

Note: To work this pattern back and forth in rows, adjust even-numbered rnds so that all knit sts are purled and all sl sts are worked with the yarn held in front.

Tuck Stitch: *With right needle, reach behind and pick up back loop of the st 4 rows below the first st on left needle (the last row of the last MC stripe). Place this st on the left needle and knit it tog with the next st on the needle. Rep from *.

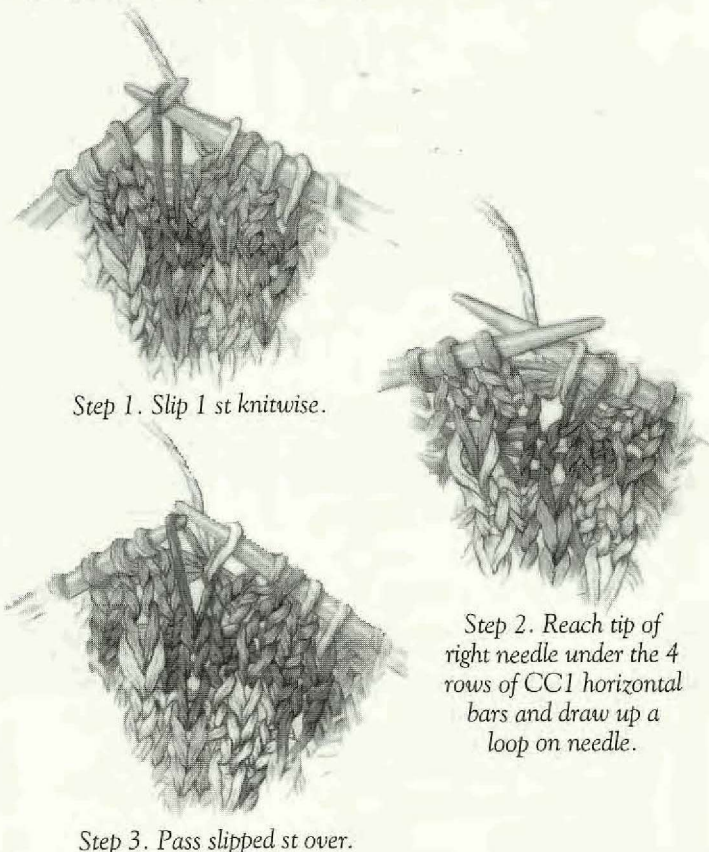

Step 1. Slip 1 st knitwise.

Step 2. Reach tip of right needle under the 4 rows of CC1 horizontal bars and draw up a loop on needle.

Step 3. Pass slipped st over.



•**Skirt:** With MC and longer needle, CO 190 (209, 228) sts. Place m and join, being careful not to twist sts. Knit 11 rnds. *With CC1, knit 4 rnds. With MC, knit 1 rnd in Tuck st, then knit 3 more rnds. Rep from * 3 more times, substituting CC2, CC3, and CC4 for CC1—1 welt of each CC. Change to MC. Cont in St st until piece measures 17 (18, 19)" (43 [46, 48.5] cm) from beg (allowing for 3" shrinkage). **Dec rnd:** Dec 70 (73, 76) sts evenly spaced—120 (136, 152) sts rem. Knit 1 rnd.

•**Bodice:** Change to shorter needle. Changing color every 4 rnds, work Slip-Stitch patt in the following color sequence: CC1, CC2, CC3, CC4, MC. Rep this color sequence for a total of 37 (41, 45) rnds, ending 4 (5, 5) sts before m. **Divide for front and back:** BO 7 (9, 9) sts for left underarm, cont in patt across 52 (58, 66) sts for front, BO 7 (9, 9) sts for right underarm, cont in patt to end—53 (59, 67) sts rem each on front and back. Work the front and back separately, working the Slip-Stitch patt back and forth in rows (adjust even-numbered rnds of patt so that all knit sts are purled and all sl sts are worked with the yarn held in front). Place back sts on holder. **Front:** Cont in patt, shape armhole by dec 1 st at each end of every RS row 3 (2, 2) times—47 (55, 63) sts rem. Cont in patt until bodice has been worked a total of 48 (52, 56) rows. **Shape neck:** (WS) Cont in patt across 20 (23, 26) sts, join new yarn, BO 7 (9, 11) sts and work rem 19 (22, 25) sts. Working both sides separately and maintaining an edge st on

each side, dec 1 st at neck edge every other row 5 (8, 7) times—15 (15, 19) sts rem each side. Cont in patt until bodice has been worked a total of 86 (94, 106) rows. Place sts on holder. **Back:** Place 53 (59, 67) back sts on needle and shape armholes as for front—47 (55, 63) sts rem. Cont in patt until bodice has been worked a total of 68 (70, 82) rows. **Shape neck:** (WS) Cont in patt across 19 (20, 24) sts, join new yarn, BO 9 (15, 15) sts and work rem 18 (19, 23) sts. Working both sides separately, dec 1 st at neck edge every 4 rows 4 (5, 5) times—15 (15, 19) sts rem each side. Cont in patt until bodice has been

worked a total of 86 (94, 106) rows. Place sts on holders.

•**Finishing:** With RS tog, BO shoulder sts tog (see Glossary, page 6). With crochet hook, work 1 row of single crochet (see page 12) around neck and armhole edges. Weave in all loose ends. Machine wash and dry on cool cycles. ∞

LeslieAnn Bestor is a yarnaholic who started Carpe Yarnum Designs to justify and finance her yarn collecting habit. During her recent move to Colorado she was embarrassed to learn that more than half of her boxes were filled with fibers and related tools of the trade.

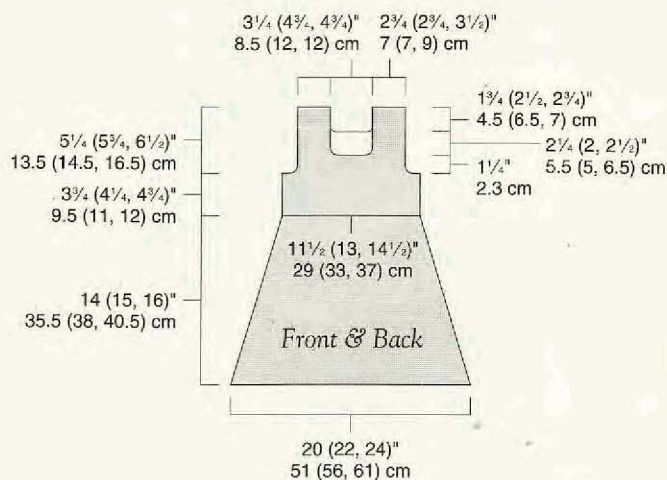

express circular needles dmc anchor pearl 12 inox needles pearl 8 cutwork linen brittany double points floss
 pearl 5 danish dmc an **THREADS & NEEDLES** needles medic
 pearl 3 metallic over hooks persian tape needles pearl 8 cutw **FOR ALL NEEDLEWORK** ver floss
 hooks wool c **FROM THE BASICS TO THE BIZARRE** flower thread afghan
 knitting yarns s **WE HAVE AN AMAZINGLY ECLECTIC STOCK** anchor pearl 12 inox
 pearl danish **CALL OR WRITE FOR OUR CATALOG** etalic overdyer crochet
 dmc anchor pearl 12 inox needles pearl 8 cutwork linen brittany doubles points pearl 5 silk cotton clover
 pearl 3 metallic overdyer c **1-800-660-4355** read afghan hooks persian tapestry
 hooks persian tapestry marlitt needles pearl 8 cutwork linen **THE NEEDLEPOINT JOINT** chet hooks wool cebelia floss
 needles pearl 8 cutwork linen opera **241 HISTORIC 25th STREET • OGDEN, UTAH 84401** brittany double points
 opera tatting shuttles medicine danish flower thread afghan hooks persian tapestry marlitt knitting yarns silk
 ribbon expres **241 HISTORIC 25th STREET • OGDEN, UTAH 84401** brittany double points
 pearl 5 silk cotton clover pearl 3 metallic overdyer crochet hooks, wool cebelia opera tatting shuttles, meici floss
 danish flower thread afghan hooks persian tapestry marlitt knitting yarn silk ribbon express circular needles

WE'RE SERIOUS ABOUT YARN

GREAT DISCOUNTS * UNMATCHED SERVICE
NAME BRAND YARNS * WEBS' EXCLUSIVE YARNS
TERRIFIC CLOSEOUTS

See why thousands of knitters have been buying natural fiber yarns from Webs for over twenty years

Introductory samples \$2.00

Tell us you saw our ad in *Interweave Knits*



Webs, Yarn Merchants
P.O. Box 147 - Service Center Road
Northampton, MA 01061-0147

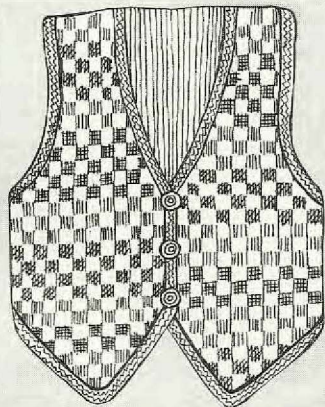

Checkerboard Vest

by **Juliane Nollan Anderson**
 Begin with a special piece of fabric for the back, add a surprise color technique in a simple fair isle pattern and you've got a one-of-a-kind creation. Pattern for Sm-Lg \$7 ppd w/photos. Send us your fabric for custom designed kit samples. Only \$7.50, which is applied to the price of the kit when purchased.

Threadbender Yarn Shop

2767 44th SW
 Grand Rapids, MI 49509
 616-531-6641
 888-531-6642 (orders only)

2 NEW

Knitting Pattern Books

by *Betty Lampen*

"Knitted
 Teddy Bears
 & Dolls"



"Best Dressed
 Teddy Bears"
 Book 3
 of "Sweaters for
 Teddy Bears"

Betty Lampen, Dept IK

2930 Jackson St.
 San Francisco, CA 94115-1007
 Books \$7 each—postage included
 CA residents include tax. US funds only.
<http://www.bettylampenknitbooks.com>

Interweave
Knits
 BACK ISSUES

Spring 1998

Creative Use of Color
More Domino Knitting

Summer 1997

Summer Knits, Bead Knitting

Fall 1996 (premier issue)

Fair Isle, Entrelac,
Gloves & Cardigans

To charge back issues of *Interweave Knits* (\$5.95 plus s&ch) to your credit card, call Dept. A-KB at 800-645-3675.

Shipping & Handling

If order totals.....Add	If order totals.....Add
\$5.51 to \$10.00.....\$3.50	\$30.01 to \$50.00.....\$5.75
\$10.01 to \$16.00.....\$4.50	\$50.01 to \$75.00.....\$6.75
\$16.01 to \$30.00.....\$5.25	Over \$75.00.....\$8.00



INTERWEAVE PRESS
 201 East Fourth Street
 Loveland, CO 80537-5655

**SpinCraft
 Patterns**

A new pattern idea

"Knit to Fit"

Use any yarn - Make it your size.
Perfect for handspun & exotic yarns.

These unique patterns let you become the designer.

- Try these collections -

Best Sweaters: six for \$12.50

Best Vests: six for \$12.50

Best Headgear: six for \$12.50

Best Accessories: six for \$12.50

send orders to:

300 Monroe, Salmon ID 83467

Save even more by subscribing to
SpinCraft Pattern Newsletter

New patterns four times a year: \$12

Ask for our Free Catalogue

for catalogue requests 10am to 6pm

call (208) 756-3076

spincraft@aol.com

**Cotton
 Yarn by
 Mail**



Call Us Toll Free!

We'll put the cotton yarns you're looking for - and more - right into your hands. Our catalog has it all! Over 1500 colors of cotton and cotton blend yarns in hundreds of weights, sizes and textures. Unique knitting kits, books, patterns, videos and tools. All with quick delivery, friendly service and a 100% Satisfaction Guarantee! Save with our bulk discounts, introductory offers and weekly specials. Plus the \$5 cost of this catalog with yarn samples is refundable with your first order.

Mail to: **ColtonClouds**
 5176 South 14th Ave., Dept IK-98
 Safford, AZ 85546-9252

Enclosed is \$5.50 (PPD) for catalog & samples



Name _____
 Address _____
 City _____ State _____ Zip _____

Credit Card Orders 800-322-7888

CONNECTIONS

Patricia Baron



Knitting in Japan

A TRADITION of space and simplicity prevails in Japanese environments. A unique sensitivity to function, as well as balance, harmony, and beauty, influences the manufacture of everyday articles. This approach is carried over into contemporary Japanese handcrafts and is clearly reflected in the garments from Japanese knitting schools.

Inspired by a world of subjects ranging from American quilts to Turkish rugs, from Chinese porcelain to European architecture, Japanese knitters are inventive and prolific. More than 120 knitting publications are produced each year, offering literally thousands of original designs. The themes are often traditionally

European with an updated or unexpected twist. For example, Fair Isle patterns are seen in geometrical interpretations or in unconventional color harmonies; cable patterns are richly embossed with pearls or beads; laces are lavishly executed and finished.

Aside from possessing dexterous knitting skills, many Japanese knitters are well educated in design. This advantage often enables them to surpass convention with uncommon creativity.

The stunning designs that arise from the Japanese schools of knitting may be considered groundbreaking in their approach to texture, motif, and composition.

Because Japan lacks an indigenous knitting history, no prior tradition structures knitters' imaginations. Designers are free to express everything that came before in Japanese culture and

much that has been borrowed from other cultures. And this work is augmented by an extraordinary design sense and modern materials and technology.

In the early 1950s, Nihon Vogue, Japan's leading needlework publisher, established a sophisticated school of handcrafts. Based in Tokyo, the school stands



Here are two of the entries received for a Yokiko Kuro design contest with the theme "The Square".

Photographs reprinted with permission of KeitoDama.



thirteen stories high with each floor devoted to a separate discipline. All facets of home-related crafts are studied, including knitting, weaving, quilting, silk flower making, sewing, crochet, cooking, and even some forms of painting.

Yo Furuta, a Japanese-American based in Carson, California, was once the United States distributor for Nihon Vogue publications. Reporting on her several visits to the Nihon Vogue school, she describes an auditorium on the top floor of the Tokyo facility where, each year, a fashion show features students' creations. Some of the more exceptional designs are photographed for publication in *KeitoDama*, Nihon Vogue's most aesthetic handcrafts magazine. The creations range from well-executed, classical sweaters and dresses to unusual, even outrageous costume statements. All are expertly constructed and obviously the product of professional tutoring. Some works are multi-media knitted pieces incorporating crochet, quilting, or even macramé. Devotés may purchase some of the handcrafted items in the wonderful boutique on the lobby level.

By the time Yo Furuta attended the school's thirtieth anniversary in 1982, some 30,000 certified instructors had passed through its doors. To be eligible for accreditation, a Nihon Vogue knitting instructor must study for seven to nine years in all disciplines of handcrafts. Once certified, the teachers are encouraged to attend workshops and seminars

on a regular basis. According to Furuta, the president of the Nihon Vogue school purchased a resort hotel in Asami where

classes can be conducted in style.

The publications of Nihon Vogue are works of art in themselves. To turn their pages is to stroll through a "museum" of needlework, graphic art, and photography. Knitted garments are sometimes modeled in con-

ventional format but are usually photographed as styled still lifes that better exhibit the designs. The photographs may be embellished with a seasonal object such as a twig or flower to convey a feeling or mood. Even endorsements for materials take on form and beauty with yarns artfully wrapped around paper cones or crescents, then arranged side by side on a textured surface.

The method of pattern presentation is almost entirely symbolic. Graphs and charts largely eliminate the need for language. Any knitter who is familiar with international symbols and the metric system can work with the patterns.

While this universal method of pattern writing has made the publications marketable in other Asian countries, particularly China and Korea, they have not succeeded in capturing a wide American and European audience. Why is this? Speaking bluntly and humorously, Yo Furuta says, "Japan does not waste time telling you how to knit!"

In other words, knitters are expected to plunge into projects without being led through preliminary steps such as casting on or adjusting for size differences. They are expected to do their own charting to accommodate desired size—patterns are presented in one size only. This kind of no-frills approach suits the Eastern sensibility better than the Western.

Most Japanese sweaters are box-cut with little or no complex shaping, so it is assumed that if you can knit, you can work the mathematics of the design. According to Furuta, the average American and European knitter still relates to a written interpretation of patterns (although this may be changing with the increased use of international symbols throughout the knitting world).

The artistic Japanese knitter has many opportunities to display, and receive critiques on, her work. Yokiko Kuro, a leading Japanese knit designer, holds a design contest which is publicized in *KeitoDama*. Ms. Kuro invites knitters throughout Japan to submit their sweaters for competition. It is obvious from winning entries that only

the most artistic need apply. Each month's contest features a different theme. Those for sweaters depicted here were "The Square" and "Turkish Design". To qualify,



The Yokiko Kuro "Turkish Design" sweater contest netted these two exquisite sweaters.

Photographs reprinted with permission of *KeitoDama*.



knitters must research their designs, then chart and knit a sweater within thirty days. Themes suggest that knitters design partially from their intellect and know-how and to some extent from their emotions and experiences.

Some Japanese knitters are so proficient that they can copy a design from observation. An English designer who was exhibiting his work at an expo in Japan experienced this first hand. He said that women attended the expo accompanied by personal knitters. Shown their clients' preferences, the knitters were able to duplicate or adapt the design directly from a swatch, without taking notes or charting. This ability to immediately comprehend and interpret a design is most likely the result of an education in diagram-based pattern reading.

In the 1980s, machine knitting swept Japan as a veritable craze. The machine-knit designs were splendid, comprising mainly womens' suits and dresses that showed amazing attention to detail. Jackets and straight skirts included darts and pleats; dresses were often flowing and drapery. Contemporary graphic patterns bordered hemlines and accented bodices. The attention given to fit and form was a particular delight for petite knitters.

After several years the craze died down and knitting machines found their way into trash bins. Literally! A California knitter traveling in Japan could not bear to see the perfectly operable knitting machines waiting to be hauled off to the dump and carted six or seven home. Lack of space in Japan, along with a general distaste for used goods and American-style garage sales, have created a society in which discarding the old is quite acceptable. Yo Furuta confirmed this philosophy, explaining that *Nihon Vogue* shreds hundreds of unsold pattern books and magazines every year. "In Japan," she says, "there is no room to store anything. Therefore, anything no longer needed is simply thrown out."

According to Furuta and Japanese nationals, Japanese knitting is experiencing a setback due to the widespread need for women to work. However, the *Nihon Vogue* School recently opened a new branch in which more than 1,000 new students enrolled for the first semester. Knitting workshops for children, some seven-and-a-half hours in length, have been advertised in recent Japanese publications.

With scores of designers and future teachers still in the process of developing their expertise, knitting may yet take its place alongside other traditional Japanese folk arts. The convention of making beauty an integral part of daily life is very much alive and well.

Patricia Baron, an avid crochet designer since the 1960s, has recently taken an interest in knitting. She teaches crochet at Saddleback College in Mission Viejo, California, and is a professional ballroom dancer and instructor.

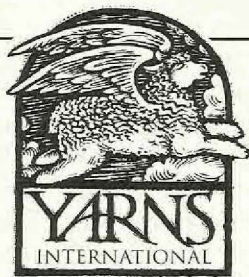

YARNS INTERNATIONAL

Your source for
ALICE STARMORE yarns
presents

Pacific Coast Highway

Alice's new pattern book
for Winter 1998

Price includes \$5 coupon
applicable to first yarn purchase.
Offer expires Dec. 31, 1998.

Knitting Seminar in Florence, Italy
April 25-May 4, 1998.
Call for information.

YARNS INTERNATIONAL

5110 Ridgefield Road • Suite 200
Bethesda, MD 20816 • (301) 913-2980

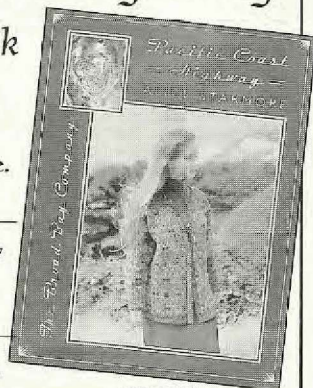

\$18.95

PLUS \$3 SHIPPING

To Order: 1-800 YARNS 2U
(1-800-927-6728)



♥ Grand View Country Store ♥

U.S. Rt. 2 Randolph, NH 03570

A UNIQUE YARN SHOP!

All the best is right here in the scenic
White Mountains of New Hampshire.
Add us to your travel agenda or send
\$3.00 to subscribe to our Newsletters
of yarns, books and original knitting
kits. Free knitting pattern in each.

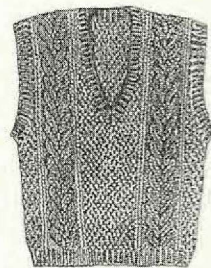

Cable V-Neck Vest

Great looking and always in
style! Knit it for Him or Her.
Berroco Cotton 100—choose
Ecru, Taupe, Sage, White, Sand,
Jade, Pink, Navy, or Wedge-
wood. Finished size 40"-46"
Complete Kit \$39.00 s/h \$5.95
Pattern Only \$3.50 s/h \$1.95

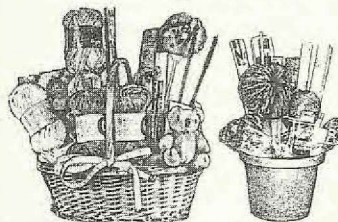

The Gift Basket Department

When you want to give (or receive) a
very special gift, order a gift basket—
Custom designed just for you or your
special knitter. Great for any occasion,
we ship anywhere. A truly unique gift.
Call us to place your order.
Prices range from \$29.99 and up.



Come for "2 Days in a Yarn Shop!"
"Mountains, Muffins and Mohair"

Other patterns from our Interweave Collection

1. Neck down Cable Yoke Cardigan
 2. Sampler V-Neck Vest—5 colors
 3. Sampler Stitch Cardigan
 4. Sampler Pullover—Him or Her
 5. Classic Sampler Jacket
- All knit in Worsted Weight Yarns
Patterns only \$3.50 each + s/h
Complete kits also available.

Call for more information.
Lodging available.
1-603-466-5715

♥ Grand View Country Store ♥ Rt. 2, Randolph, NH 03570 1-800-898-5715

THE Web-sters



THE JEAN MOSS BOOK OF
**WORLD
KNITS**

BOOK \$27.95 + S&H

JEAN MOSS
2-DAY WORKSHOP
MARCH 27 & 28
Call now for reservations

Free COLOR CATALOG
1-800-482-9801
11 N. MAIN STREET
ASHLAND, OR 97520

HANDSPINNERS WEAVERS & KNITTERS

Alice Starmore
Rowan
Fiesta Yarns
Philosopher's Wool Co.
Dale of Norway
Tahki
Brown Sheep
Vittadini
Creative Yarns
Manos
Cynthia Helene
Lorna's Laces
Mountain Colors
Stahl
Jo Sharp
Green Mountain
Berroco
Annabel Fox
Classic Elite
Prism
Noro
Crystal Palace
Froehlich



QIVIUT

ALASKAN HANDKNITS

by Musk Ox Producers' Co-Operative



A unique gift of wearable masterpieces.

- Native owned cooperative since 1969
- Exclusive garments in Alaskan village patterns
- Hand-knitted by over 200 Eskimo knitters

OOMINGMAK

Downtown Location • Corner of 6th & H

Little brown house with musk ox mural

604 H Street, Anchorage, AK 99501 • (907) 272-9225

FRENCH YARNS

FOR HANDKNITTING, MACHINE-KNITTING, & NEEDLEPOINT

JASMINE® SILK, PARISIAN COTTON®,

BELANGOR® ANGORA,

KILHIM® EGYPTIAN COTTON,

MERINO KING®, ECOWOOL®,

FLORE® KID MOHAIR,

KISMET® METALLIC,

CASHMERE & WOOL,

CASHMERE & SILK BLENDS.

SUPPLYING RETAIL STORES, DESIGNERS,

MANUFACTURERS & KIT MAKERS

FOR INFORMATION &/OR ALBUM PLEASE CALL

1-800-836-3314

Galler Yarns

JOSEPH GALLER YARNS, INC.

MONROE, NEW YORK 10950-9736



Knit & Crochet Patterns for Modern Dolls & Soft Animals*

11 Different Books

* Popular dolls 18"–20" including American Girl® collection from Pleasant Co., 16"–18" bunnies and bears.



For detailed pattern information, please send a SASE to:

Close Knit Press/Te Corporation
POB 1500 Dept IK Campton, NH 03223-1500

Voice: 603 726-4700

e-mail: dolls@tecorp.com

Fax: 603 726-8818

Web: <http://www.tecorp.com>

Patterns for those who love to knit...for those they love

Knit with the Best...

Join the Knitting Guild of America now membership includes a subscription to *CAST ON* magazine and much more!

- Innovative Designs
- Great How-To Articles
- Knitting News
- Master Knitting Programs for Hand and Machine
- 1998 National Convention in **Milwaukee, WI, March 25-29, 1998**
- Fabulous 1998 Conferences in:
Columbus, OH—June 3-7; Statewide Meeting, Tacoma, WA—July 31-August 2; Springfield, IL—Aug. 21-23; Colorado Springs, CO—Sept. 25-27; Andover, MA—Nov. 11-15.

To join TKGA send a check for \$23 (\$30 for Canada and Mexico, \$38 for all others) to TKGA or call **1-800-274-6034** to use Visa or MasterCard. For information, call (423) 524-2401 or see our web site at <http://www.tkga.com>

TKGA, Dept. IK3 • P.O.

Box 1606 • Knoxville, TN 37901-1606



Name _____

Address _____

City _____ St _____ Zip+4 _____

Telephone _____ E-mail _____

MC VISA Exp. date _____

FOLK LORE

Robin Hansen



Money Cats, Knitty Kitties— A Lexicologist and Knitter Takes a Cat Trip

YOU PUT MONEY IN THEM, you take money out of them. You find them under beds and under chairs, scampering away from the dust mop or vacuum cleaner. They sit in your lap and play with your yarn as you knit.

I'm talking about kitties—money kitties, dust kitties, and cat kitties. Meg Swanson recommends books about cats in her *Woolgathering* newsletter and suggests we think of cats—or kitties—as part of our knitting equipment. “Let’s see . . . needles . . . yarn . . . cat . . .,” she lists. Although I’ve never heard of anyone knitting cat hair, cats and kitties have been associated with fiber work the world over. The image of grandmother knitting by the fireplace is incomplete without a kitten curled up on the braided rug at her feet. In some Germanic languages, the word for purring is the same as the word for spinning. Is it because a cat’s purr sounds like the whir of a spinning wheel? Why would anyone think of that if the cat were not right there, next to the spinning wheel, making the same noise?

The dust kitten under the bed is obviously a cousin of the gray tabby on the eiderdown. We may say, “Take some money out of the kitty” when we send a coworker for cream for the coffee. This “kitty” is a gambling term that means the same as “pot” (“Put some money in the pot”), where “pot” indicates a collection of money that won’t be used for gambling but for refreshments. So this “kitty” may be a nickname for “kettle”. Maybe.

cation tag from a heavy silk kumihimo collar. These cats sit with one forepaw raised in the Japanese gesture of beckoning. Legend has it that, once upon a time, two (poor, starving, freezing, Japanese) orphan children were beckoned in this manner by a cat; when they followed it, they were shown a treasure trove of gold coins that kept them in wealth to the end of their days.

My cat raises his paw, too, but turned sideways. For him it means, “Feed me!” or “Let me out!” He has never led me to a pot of gold.

Have you heard of calico cats being called “money cats”? Either P.T. Barnum or Florenz Ziegfield is said to have offered \$10,000 for a male calico. He never had to pay up, because apparently calicoism is a female sex-linked trait in cats, and there are no males. But the money-cat name stuck.

In Denmark, an old-style coin purse is called a “pengekatt”—a money cat or kitty. As a visual pun, they are sometimes knitted with a cat’s face and hanging paws and tails like the one shown here. They are purses in the medieval style, the sort flung around in Shakespearean plays, like a double-toed sock with a slit in the middle of one side and, often, two rings that slide toward the “toes” to secure the cash. With coins in both ends, a money cat can be hung over the belt or used for sandbagging an intruder.



Japanese businesses often have a kitty bank prominently displayed—a large, ceramic, black-and-white cat, sporting a large gold coin dangling like an identifi-

My mother-in-law kept a garter-stitch coin cat on a coat hook near her front door, full of coins for commuting by train. It had a cat’s face, and this is how she made it. 

COIN KITTY

This kitty is made from a garter-stitch rectangle that measures 4¼" (11 cm) wide and 6" (15 cm) long. The square face is knitted onto the rectangle, and the legs and tail are separate garter-stitch rectangles. The side of the body remains open for easy access to your coins.

FINISHED SIZE 2¼" (5.5 cm) wide by 10" (25.5 cm) long.

YARN Sport-weight: one 50g ball.

NEEDLES Size 4 (3.5 mm).

NOTIONS Two buttons for eyes; short lengths of embroidery thread for nose and mouth; short length of monofilament fishing line for whiskers, if desired; waste yarn.

GAUGE 13 sts and 23 rows = 2" (5 cm) in garter st. The exact gauge is unimportant as long as the kitty is large enough to be practical.

Body: CO 26 sts. Knit 68 rows. BO

13 sts. **Head:** Knit rem 13 sts for 22 rows. **Ears:** *K4, turn, k4, turn, knit to end of row. Rep from * for other ear. Knit 1 row. BO all sts and break yarn, leaving an 18" (46 cm) tail. **Legs:** (Make 4) CO 10 sts. Knit 30 rows. BO all sts and break yarn, leaving an 18" (46 cm) tail. Thread tail on a tapestry needle and use it to gather the BO edge tightly to close the foot end and then sew the side seam, stopping partway to stuff the foot and leg with waste yarn. **Tail:** CO 7 sts. Knit 42 rows. BO all sts and break yarn, leaving a 12" (30.5 cm) tail. Thread tail on a tapestry needle and use it to gather the BO edge and then sew the side seam. Make a curl in the tip of the tail by pulling on the yarn used to sew the seam and sliding the resulting gathers to tip.

Finishing: Face: Decorate face with buttons for eyes and embroidery for mouth and nose (buttonhole silk sewn over a tiny diamond-shaped piece of paper). Use monofilament fishing line

knotted behind the nose for whiskers, if desired. **Assembly:** Fold body in half lengthwise. Fold face back onto body (WS of face to RS of body), and with yarn threaded on a tapestry needle, sew left side of face (except ear) to body. Sew across "chin", gathering it slightly to give a rounded shape. Then sew right side of face (except ear), attaching it to body front and back, and cont sewing to 1" (2.5 cm) from center of body. Stuff head lightly with waste yarn, then sew top of head between ears to body, leaving ears free. Sew two (front) legs to underside of body just behind the head, so that the seams face out. Sew two (back) legs to other end of body, also with the seams facing out. Sew the side to 1" (2.5 cm) from center of body, so that the opening is a total of 2" (5 cm) long. Sew tail onto back of body about ½" (1.3 cm) from edge. Fill both ends of the kitty with coins and hang it just under its forelegs for a cattish look.

addi Turbo® needles

the choice of professional knitters

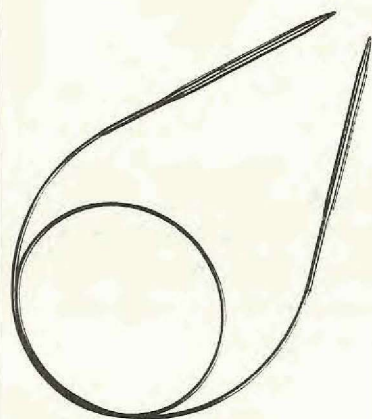

Slick tips, smooth joints and pliable cords have made the addi Turbo® circular needle the choice for professional knitters for years! Isn't it time you joined them?

Available in 8 lengths from 12" to 60" and in 19 sizes ranging from a US 000 to a US 36.

available in fine yarn shops

Exclusive Distributor

skacel collection, Inc.

PO Box 88110, Seattle, WA 98138-2110

Phone: (253) 854-2710

Fax: (253) 854-2571



When you get right down to it, it's the color and...color is our business.

Yarns for Knitting & Weaving

You will be pleasantly surprised by our new, lower retail prices!

Call for information: 800-338-9415

Yarn Catalog - \$6



HARRISVILLE DESIGNS

Center Village, Box 806-39

Harrisville, New Hampshire 03450

DESIGNS BY JUDITH

Kids Knits

Pattern D507

Pullover,
cardigan
& hat
in lots
of sizes
& gauges

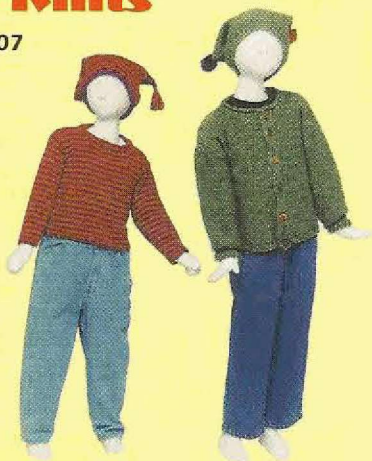

Look for my entire collection of easy-to-knit, fashionable designs for adults and children in yarn shops & needlework catalogs.

Judith Stangl

DESIGNS BY JUDITH PO BOX 770 MEDFORD, MA 02155 (781) 438-9631

SOURCES FOR SUPPLIES

(W) = Wholesale (R) = Retail

YARNS

Yarns used in this issue are available through your local retail store or mail order company. If you are unable to locate the supplies, below is a listing of the U.S. distributors. Write to them for a retail source.

(W) Berroco Inc/Lang, 14 Elmdale Rd, PO Box 367, Uxbridge, MA 01569.

(W) Brown Sheep Company, 100662 County Rd 16, Mitchell, NE 69357.

(R) Cherry Tree Hill Yarn, Chery Tree Hill Rd., East Montpelier, VT 05651.

(W) Classic Elite Yarns, 12 Perkins St, Lowell, MA 01854.

(W) Muench Yarns/GGH, 118 Ricardo Rd, Mill Valley, CA 94941-2461.

(W) Schaefer Yarns, Kelley's Corners, Interlaken, NY 14847.

(W) Tahki Yarns/Stahl Wolle, 11 Graphic Pl, Moonachie, NJ 07074.

(W) Westminster Fibers/Rowan Yarns, 5 Northern Blvd, Amherst, NH 03031.

Color Trip WITH DEB MENZ!

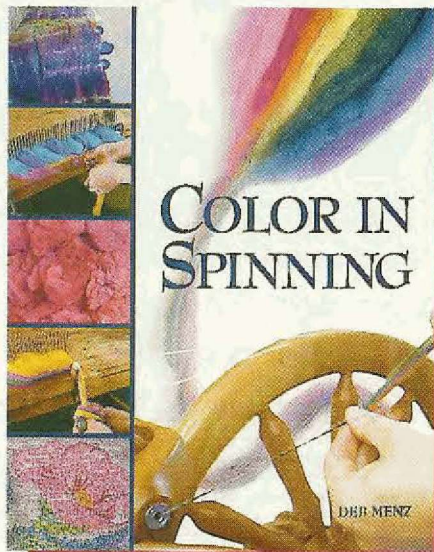

8½ × 11, clothbound, 240 pages, 150 color photos. #690—\$39.95. Available in April.

Written expressly for the handspinner seeking new adventures in color, this comprehensive manual combines an accessible approach with technical savvy. Starting with the basics of the color/fiber relationship, Deb Menz presents in-depth discussions and demonstrations of immersion dyeing, painting rovings, blending colors and fibers with a drum carder, multicolor combing techniques, and spinning and plying multicolored preparations. The novice will find a world of color to learn from while the expert will appreciate the author's insightful techniques. Everyone will welcome the extensive photos of dyed spun fiber and the step-by-step processes to achieve it.

Find *Color in Spinning* at your local craft source or call Interweave Books, Dept. IWPK, at **800-289-9276**.

 INTERWEAVE PRESS
201 East Fourth Street Loveland, CO 80537-5655
<http://www.interweave.com>



Knitting Slumber

We like to think up useful projects that fit the demands of busy days. A few of us were inspired after taking Valentina Devine's workshop and cogitated for weeks over the possibilities of Creative Knitting (see pages 8–15). We decided to knit a staff afghan. We put together a stash of yarns in mostly blues, greens, and purples, and we each knit a 14" square, hoping they would work together visually. We were warned that Creative Knitting could be addictive, and it was. Many of us came to work blurry-eyed from staying up half the night knitting. As our squares progressed, each taking on a different look, we were doubtful that the afghan would be anything but ghastly. But now that the squares are crocheted together with a common border, we think it looks terrific!

Ann Budd
Editorial

Amy Clarke
Editorial

Nancy Disney
Events



Jennifer Nastu
Marketing

Jillian Moreno
Publishing

Marilyn Murphy
Editorial

(My square is in the middle; I'm lying under Dot Ratigan's square. Dot's our technical editor and, fortunately for her, lives too far away to have her photo taken for such silliness.)

Susan Strawn Bailey
Illustration

Judith Durant
Editorial

Learn from Videos

Aren't near a store or knitting instructor?
Don't have time for a multi-week class?



Then learn from a video at your leisure.
Re-play when you missed something,
turn it on when you have time,
ask a friend over and learn together.

VICTORIAN
VIDEO

Free Catalog
Call
1-800-848-0284

Cardigan Details

by Meg Swansen. \$29.95

Knitting: Multi-Color Techniques

by Susie Hodges. \$39.95

Knit-Weave Technique

by Linda McGurn. \$29.95

Sock Video

by Nancy Wiseman. \$19.95

Knitting Glossary

by Zimmermann & Swansen. \$66.95



Yarn Barn/Victorian Video
930 Massachusetts
Lawrence, KS 66044



FIBER KINGDOM

fibers and colors to delight your senses

FROM THE NORTH COUNTRY OF NEW YORK STATE



Unique natural fiber yarns hand-dyed in harmonious color palettes
Original design kits
Special buttons, dyes, books, Addi Turbo needles
Fibers and equipment for spinners, weavers, felters
Workshops, personalized instruction

SEND LSASE FOR PRODUCT INFORMATION TO:

SYLVIA GRAHAM, FIBER KINGDOM BOX 654 EAST BROADWAY
SALEM, N.Y. 12865 518 854 7225 PHONE/FAX

the mannings Handweaving School & Supply Center



1132 Green Ridge Rd
PO Box 687
East Berlin, PA 17316
717-624-2223

ORDERS - 1-800-233-7166

We stock what every knitter needs: Knitting Books (189 titles), patterns from Ann Norling, Fiber Trends, Woolen collectibles, etc., yarns from Brown Sheep, JCA, Henry's Attic, Renaissance, Tahki, Plymouth, Skacel, etc., knitting needles, NEW wooden cable needles, and a large selection of the popular sock yarns. \$2.50 FOR CATALOG AND YARN STYLE CARD

UNICORN
BOOKS AND CRAFTS, INC.

The Complete Resource for Knitting and Needlework Books

Many yarn and needlework stores across the country stock the books we distribute. Check with your local store or send \$3.00 to:
Unicorn Books and Crafts
1338 Ross Street
Petaluma, California 94954-1125
and we'll send you a copy of our catalog.
Phone: 707-762-3362
Fax: 707-762-0335

Fiber Trends®

Hand Knit Designs

Knit & Felt Your Own Woolly

Sheep

See the Full Line of Fiber Trends Patterns
At Your Favorite Yarn Store



Retailers, if you would like to carry Fiber Trends patterns in your store call:

Bryson Distributing @ 800/544-8992
or contact Fiber Trends at

Fiber Trends • 304 36th Street #173 • Bellingham, WA 98225 • Phone (360) 733-5997 • Fax (360) 733-4896

Moving? If you're planning a move, don't forget to take along your INTERWEAVE KNITS subscription. Send your old and new addresses, along with the customer number that appears on your mailing label, to:

INTERWEAVE KNITS
Change of Address
201 East Fourth Street
Loveland, CO 80537-5655



PRODUCT NEWS

Jillian Moreno

BOOK NOTES

The Jean Moss Book of World Knits

Jean Moss

Taunton Press, \$27.95

In her latest book, Jean Moss brings the world to your knitting basket. Thirty-six projects showcase rich pattern and color from cultures as diverse as Shoowan, Mayan, Irish, and Palestinian. Projects including sweaters, hats, socks, pillows, and throws are

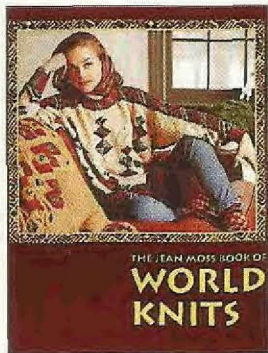

fully charted and shown in a variety of colorways. Grab your needles and start knitting your way around the world.

Available from your local yarn shop or Taunton Press (800) 888-8286.

Mosaic Knitting

Barbara G. Walker

Schoolhouse Press, \$31.95

Love the look of color knitting, but are intimidated by intarsia and Fair Isle? Try mosaic knitting, a nearly effortless and stress-free type of two-color knitting. Three hundred eighty mosaics from the nimble fingers of Barbara Walker are waiting to help you conquer your color fears and deplete your yarn stash.

Available from your local yarn shop or Schoolhouse Press (800) 968-5648.

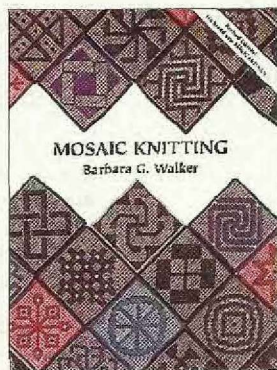

Colorful Knits for You and Your Child

Zoë Mellor

Trafalgar Square Publishing, \$22.95

Elephants, pirates, hearts, flowers, dogs, and butterflies scamper over twenty-five original designs for women and children. Brilliant colors and whimsical patterns

make these garments from new designer Zoë Mellor irresistible for kids and their designated knitters.

Available from your local yarn shop or Trafalgar Square Publishing (800) 423-4225.

Traditional Lace Knitting

Furze Hewitt

Kangaroo Press, \$29.95

With this collection of lace knitting projects, Australian knitter Furze Hewitt has recreated a time of elegance and grace. Lace tablecloths, pillow edgings, doilies, coverlets, and curtains are some of the forty traditional projects included in this lovely book.

Available from your local yarn shop or Unicorn Books and Crafts (800) 289-9276.

Pacific Coast Highway

Alice Starmore

The Broad Bay Company, \$18.95

The latest pattern book from Alice Starmore draws its inspiration from the portion of California from San Francisco to

Fort Bragg. Fifteen garments for women, men, and children are beautifully photographed along the Pacific coast. Starmore's usual attention to detail, design, and color are shown in intricate Fair Isles and undulating Arans. Alice's daughter Jade has joined her mother with a spectacular debut—she contributes a baby blanket and two sweaters, one of which,

Fort Ross, is the standout in the book.

Available from your local yarn shop or Unicorn Books and Crafts (800) 289-9276.

PATTERNS

Bears and Rabbits to Knit

Bear Brain Creations, \$5.00 each

I know what you're thinking. "Not another knitted felted animal!" Admittedly,

I thought the same at first. But these are worth a look. Bears with overstuffed tummies and four different faces; a rabbit with feet so large he's sure to raise a smile from even the most bunnyed-out knitter. Available from your local yarn shop.

Custom Fit Socks and Mittens

The Fiber Gypsy, \$5.00 each

Would you like to make perfectly-fitting socks and mittens from any yarn you choose? It's now possible with four patterns from the Fiber Gypsy. Each booklet has worksheets that allow you to make any size mitten or sock with any gauge yarn. Also included are tips and tricks and a chart that gives you approximate measurements for men, women, and children.

Available from your local yarn shop or The Fiber Gypsy (407) 898-9439, <http://www.benefitslink.com/knit/gypsy>

YARN

Pine Tree Yarns Handpainted Yarns

Inspired by the natural beauty of coastal Maine, Elaine Davey handpaints beautiful, subtle yarn. I hate to call these yarns "variegated"—that word may conjure images of abrupt and clunky color changes. Perhaps straticulated is better. Think of the color changes in a piece of marble or a sunset. If you are looking for yarn for a special project, Maine Pine Tree Handpaints may be just the ticket. \$17 per 250 yard/4-ounce skein. Available from Pine Tree Yarns (207) 563-8909.

Icelandic Laceweight Wool

All you lace-aholics take note—there's a new yarn in town. Especially gorgeous knitted into a shawl, this yarn can be used for any lace project you have in mind, including socks. Culled from long-fibered Icelandic sheep, it comes in seven natural shades and twelve dyed colors from the subtlest lilac to fire-engine red.

\$8.50 for a 100-gm skein or \$4.25 for a 50-gm ball. Available from Schoolhouse Press (800) 968-5648. ∞

**Treat Yourself to a
Week of Pure Luxury!**
Cook no meals! Do no laundry!
Wash no dishes!

**Knit all week and learn new
techniques, guilt free!**

Knit Away In the Rockies
July 20-25 or Sept. 14-19, 1998
Winter Park, Colorado

Knit Away In Taos, New Mexico
October 8-11, 1998

Daily workshops with time to knit and enjoy the scenery. Stay in comfort at a secluded lodge with good food and private accommodations. This Year's theme is "Colorful Knitting". The workshops will include techniques for both color knitting and practical color theory.

For information contact: Cheryl Oberle,
Knitting Designer and Teacher,
3317 Newton St., Denver, CO 80211
e-mail: oberleknits@worldnet.att.net
(303) 433-9205



15th Annual WOOL FESTIVAL



at Taos

60 Booths • Demonstrations • Auction • Food Booths

Kit Carson Park • Taos, NM • (505) 751-0306 for info.

October 3 & 4, 1998 • 9am-5pm each day

GIVE YOUR SWEATERS THE TLC THEY REALLY NEED WITH

Eucalan No-Rinse Woolwash

Woolwash cleans and conditions in one easy step... there's no rinsing! The natural lanolin conditions the fibers while the fresh smelling eucalyptus helps protect against moths. Woolwash is ideal for use by hand or machine.

(Always store your sweaters clean.)

- Safe for all fine washables
- Contains no harsh chemicals
- Not tested on animals
- Earth friendly

Available from fine yarn stores everywhere.

For a free sample (one per household please), send a copy of this ad and a postage stamp to:

USA: Eucalan Sample
Department B
9861 Holland-Glenwood Rd.
Glenwood, NY 14069

CANADA: Eucalan Sample
Department B
PO Box 374
Paris, ON, Canada N3L 3T5

PARIS SOUTHERN LIGHTS, INC.
1-800-561-9731 Dealer Inquiries Welcome
Sold under the trade name "Eucalan" in Canada



ADVERTISERS' INDEX

A Stitch Above	55	Mountain Colors	33
Amazing Threads	51	Muench Yarns	15
Aylin's Woolgatherer	59	Nancie Knits	44
Barkim, Ltd.	59	Needlepoint Joint, The	62
Book of the Month Club	3	Oberle Knitting Camp	74
Borealis Sweaterscapes	33	Oomingmak, Musk Ox Producers	66
Brittany Company	45	Paris Southern Lights	74
Carolina Homespun	30	Patternworks	17
Cherry Tree Hill Yarn	51	Personal Threads Boutique	55
Coats Patons	bc	Rovings	ibc
Cottage Creations	44	Samuel Charis Knits	59
Cotton Clouds	63	Schaefer Yarns	21
Crystal Palace Yarns	45	Schoolhouse Press	16
Dale of Norway	17	Shuttles, Spindles & Skeins	30
Designs by Judith	70	Skacel Collection	69
Featheridge Designs	33	Spincraft Pattern Newsletter	63
Fiber Fantasy	33	Susan's Fiber Shop	59
Fiber Trends	72	Sylvia Graham, Fiber Kingdom	72
Fibretech	51	Tahki Yarns	7
Floucault Handknits	44	Taos Wool Festival	74
Grand View Country Store	66	Taunton Press	5
Halcyon Yarn	29	Te Corporation	67
Harrisville Designs	69	Tess' Designer Yarns	29
Interweave Knits	16, 52, 55, 58, 63, 70	Threadbender Yarn Shop	63
Joseph Galler, Inc.	67	Unicorn Books & Crafts, Inc. ...	72
Knitting Guild of America	67	Victorian Video	72
Knitting Traditions	59	Web*sters	66
L'Atelier	ifc	Webs	63
Lambspin of Colorado	29	Westminster Fibers	33
Lampen, Betty	63	Wool Connection	16
Lion Brand Yarn Co.	58	Wooly West	17
Louet Sales	30	Yarn Barn	45
Machine Knitters Source	17	Yarns International	66
Mannings, The	72		

The Knits Resource Guide



**HAND-DYED
KNITTING
YARNS**

Samples & Color Catalog \$19.00
Color Catalog \$3.50
800.765.1272 or 505.758.0433

**RIO GRANDE
WEAVERS SUPPLY**
216 B Pueblo Norte, Taos, NM 87571

**Beautiful Bolivian
ALPACA YARN**

100% alpaca yarn in 90+ colors!
sport weight 2 oz., 2-ply, 115 yard skeins
\$6.20 per skein, \$4.34 per skein for orders over 50+ skeins
Send \$2 and SASE legal size envelope for color/sample card to:
Blue Sky Alpacas, P.O. box 387, St. Francis, MN 55070
612-753-5815, e-mail bluesky@visi.com, web site: <http://racparker.com/bluesky/>
I apologize for any inconvenience I may have caused you. I published the wrong phone number in the last issue of Interweave Knits, My mistake! - Linda of Blue Sky Alpacas



Lustrous Yarns from Long Stapled Corriedale and Mohair Wool
77 Natural & dyed Colors *Sample Card \$10.00*

Bear Hill Farm
Integrity in Wool
13 Bear Hill Road ~ Bozrah, CT 06334 ~ (860)889-1719
Est. 1730 *Sonja Pedersen Fuller*

Great Yarns 1208 Ridge Road Raleigh, NC 27607 919-832-3599

Specialty & Unusual Yarns from all over the world!
Simple patterns become Elegant! Fun! Colorful! Easy!
Send \$5.00 for our quarterly mailings. Future issues are free!
Mailings include lots of current info on yarns & supplies available.

1-800-810-0045 Order Line

Classic Elite • Cynthia Helene • Adrienne Vittadini • Filatura Di Crosa • Prism
Colinette • Unger • Lang • Berroco • Swedish Yarns • Missoni • Muench

Austerman, Brown Sheep, Cleckheaton, Hayfield, Lane Borgosesia, Patons, Plymouth, Shepherd, Sirdar, Skacel, Stahl, Tahki

Brittany needles and hooks
Books, Patterns
Kits, Accessories

Elegant Stitches
14115 S. Dixie Hwy
Miami FL 33176
(305) 232-4005 elegantst@aol.com
<http://members.aol.com/elegantst/index.html>

HANDCRAFTED PORCELAIN BUTTONS
MADE IN ENGLAND



7/8" - \$3.50 5/8" - \$3.00 Machine Washable
For picture of complete selection of buttons, send \$2.00
Mail Orders Welcome
1 800 489-4969

Three Kittens Yarn Shoppe
805 Sibley Memorial Hwy., St. Paul, MN 55118

Wholesale inquiries

Viva! Chinchilla.
"TOUCH A CLOUD"



Introductory Offer
Baby Bootie Kit including pattern and yarn: \$7.50

For samples and information send \$3 to
Creature Comforts PO Box 606 Vashon Island, WA 98070 206 463-2004

Vittadini • Colinette • Tahki • Classic Elite • Plymouth • Crystal Palace

CLASSES
Call for Details

Yarns By Design
247 E. Wisconsin Ave., Neenah, WI 54956 (920) 727-0530
Toll Free 1-888-55-YARNS
Knitting, Spinning, Weaving, Classes, Specialty Sweaters
Product Listing \$1.00
Located near Downtown in Historic Westover House—
MON., THURS., FRI 10-8; TUES., WED., SAT. 10-5



Brown Sheep • Alice Starmore • Dale of Norway

The Knits Resource Guide



PURE WOOL
Since 1821

100% WOOL YARNS

Blues, laurels, roses & greens—over 76 shades—heathers, all-naturals, solids, marls, tweeds. Lanolin-rich, pure wool. Ideal for classic sweaters, cozy caps & mittens. Thrifty 4-oz. skeins. Ask us for dealer names & FREE color packs.

Bartlettyarns, Inc.

Box 36-KS7 Harmony ME 04942 207/683-2251

Pamper Yourself...

Luxurious AMERICAN CASHMERE

from herds all across America



100% CASHMERE Yarn
CASHMERE Blend Yarns
Ready-To-Spin CASHMERE Fiber

To order, call/write:

CASHMERE AMERICA COOPERATIVE

P.O. Box 1126, Sonora, TX 76950,
(915) 387-6052 (Tu or Th)

or a Dir. at (360) 424-7935 (WA), or (207) 336-2948 (ME)



Ewe & Eye

Exotic Yarns ♥ Needlepoint ♥ Cross Stitch
Educational Toys ♥ Exclusive Gifts

NEW! Patterns ♥ Buttons ♥ Classes

Knitting Machines starting at \$299.00.

512 River Road
Boerne, TX 78006
(210) 249-2083

www.dyedinthewool.com

VISA/MC
Orders: 1-888-249-2083
Will ship.
We speak Czech!

Early Bird Special!

Save 15% until 5-15-98

Orders placed before May 15th
for yarn required for designs in this issue
of *Knits* will receive a 15% discount.

Call 1-800-676-9813 for Details.

We Have
All The Newest
Knitting Books & Patterns

NANCY'S KNITWORKS

1650 West Wabash, Suite 1, Springfield, IL 62704



Catalog \$3
Free With Order
Visa/MC
Discover

...your source for name brand
yarns and other knitting supplies
at great prices...



Order FREE brochure today!

Complete ring binder catalog \$10 ppd.
\$7 ref. with order of \$50

1-888-226-YARN

1509 Burning Lantern Lane**Kannapolis, NC 28081

HANDSPUN & NATURALLY DYED YARN

RAINBOW SKEINS

Worsted weight - 20yds. each of seven colors

100% Wool - \$10.00
ANGORA/WOOL BLEND - \$19.00

SAMPLES & BROCHURE \$ 4.00

JAMIE HARMON

RD 3 BOX 464-T
JERICHO, VT 05465

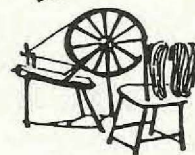

Himalayan Dream

Handspun yarn from women in Nepal

Angora, Silk, Cotton, Allo (Himalayan Nettle)

Request our free brochure
PO Box 585, Burlington, WI 53105-0585
Phone/fax: (414) 763-0923 • email: nepalone@bbw.tds.net
Hard drive crashed!
Interested email customers please respond again.

Nordic Fiber Arts



You'll LOVE our
RAUMA YARNS & NOVI NEEDLES

Highest Quality - Lowest Prices
Best selection of Color & Sizes

FREE CATALOG

4 Cutts Road • Durham, NH 03824 • 603-868-1196

The Knits Resource Guide

Gemini Fibres

is your Canadian retail source for all your Knitting Supplies

* best book selection—all the latest titles *

* Videos to rent or purchase *

* Fibre Trend Patterns, Knitting Bracelets, McMorran Yarn Balance *

* Ontario's Dealer for Harrisville Designs Yarn *

* Hand-painted Unspun Scarf Kits & Hand-dyed Yarns *

* Canadian & Norwegian Pewter * **Brittany Knitting Needles** *

We also carry a full line of weaving and spinning supplies.

MAIL ORDERS WELCOME / PRICE LIST with SASE



Gemini Fibres
5062 Mount Albert Road East
Mount Albert, ON L0G 1M0 Toll Free: 1-800-564-9665
Tel: 905-473-1033 / Fax: 905-473-6544



Fine Quality Yarns

Silk yarn \$52/lb	Kid Mohair buckled yarn, made in Italy, beautifully rainbow dyed \$99/lb
Cashmere yarn \$52/lb	Baby Alpaca yarn color . \$75/lb
Cashmere/silk yarn \$52/lb	Merino yarn natural . . . \$15/lb
Camel down yarn \$52/lb	Mill end novelty yarns closed out \$5/lb
Yak down yarn \$52/lb	
Virgin Wool yarn color . \$38/lb	
Egyptian cotton yarn . . . \$60/lb	

Luchi Yarns, 1055 E. Paramount Pkwy., Batavia, IL 60510
(630) 761-9674. \$10.00 for sample color card.

SOFT WOOL YARN

Merino-Rambouillet fine grade wool

Worsted & Sport weight

Natural & Dyed colors

Skeins & Cones

3 colors 100% CHEMICAL FREE

New Zealand
Knitting Needles
SP pr. 2 thru 11
DP swt/4-2 thru 8
\$4.75 pair or set
plus \$4 shipping



Send Long SASE for free brochure and color samples to:

MARR HAVEN

772 - 39TH ST., DEPT IK ALLEGAN, MI 49010

(616) 673-8800 • <http://www.accn.org/~mhyarn>

Heavenly Cotton Facecloths

VOL. 1—Five elegant facecloths to knit and enjoy.

VOL. 2—Five more facecloths to knit, featuring applied lace edgings.

Heavenly Cotton Soap Socks and more . . .

Four patterns for soap socks and two patterns for French hand mitts.



All patterns are \$8.75 each. Make check payable to

The Heirloom Knitter,

Barbara Scoville, 9729 Sweet Blossom Dr.,
South Jordan, Utah 84095 • 1-800-253-3606

knitting

NOW

A Newsletter for the Serious Knitter

In the **SPRING/SUMMER '98 ISSUE:**

Sweaters for Boys & Girls • "Stash Pillows"

A Great Baby Afghan & Much More!

PLUS Interviews, Articles & Reviews!

Send for Sample Issue: \$4.25 plus .75 postage to:

KNITTING NOW • P.O. Box 353-IN5 Norfolk • MA 02056

508-528-3289

Visit our Web Page at: <http://users.aol.com/knitnow/>
e-mail: KnitNOW@aol.com

These Lacey Cotton Socks,
designed by
Charlene Anderson-Sims,
are quick to knit and
fun to wear.
They're in the
Spring/Summer '98 issue of
Knitting NOW!

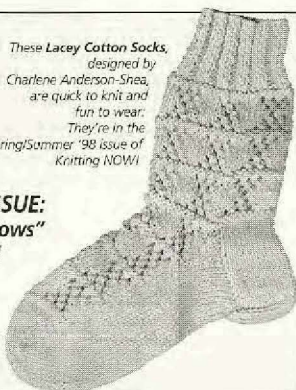

The Fiber Studio

New Hampshire's Leading Fiber Arts Store

- ◆ Cynthia Helene ◆ Brown Sheep ◆ Reynolds
- ◆ Froelich ◆ Classic Elite ◆ Peace Fleece
- ◆ Dale of Norway ◆ Knitting Fever ◆ Patons
- ◆ Crystal Palace ◆ Lana Borgosesia ◆ Tahki
- ◆ Close-out yarns ◆ Looms ◆ Spinning Wheels



Yarn Samples \$5.00 set Catalog \$1.00

9 Foster Hill Rd., PO Box 637, Henniker, NH 03242

603-428-7830 Open Tues-Sat, 10-4 Sun by Chance

<http://www.conknet.com/fiberstudio> fiberstudio@conknet.com



SCHOOL PRODUCTS CO., INC.

Come look us over for

The Widest Selection of Designer Yarns Anywhere!

Looms, Brother Knitting Machines,
Accessories, Books, Videos and More!

Big Selection-Big Discounts

Mail Orders Available

e-mail: berta@schoolproducts.com <http://www.schoolproducts.com>

1201 Broadway, New York, NY 10001

212-679-3516

Affordable hand-dyed Yarns from...

Colorflow



EJ Merino - Bohus yarn packs

Over 70 colors of 100% wool in 4 weights

311 S. Van Buren
Lancaster, WI. 53813

dyebat@pcii.net
608-723-7902

The Knits Resource Guide

The Button Shoppe

BUTTONS BY MAIL

The Button Shoppe has one of the largest collections of buttons to complete your special handwork or fiber arts project. We carry an extensive selection of metal and synthetic fashion buttons, a glittering array of crystal and pearl buttons, natural material buttons made from horn, shell, wood, tagua nut, and stone, and even fun and fanciful novelty buttons from airplanes to zebras.

SEE THE LATEST BUTTONS IN OUR NEW CATALOG



The Button Shoppe

Catalog Dept. IK-298
4744 Oakfield Circle
Carmichael, CA 95608

16-page color catalog
\$5.00 (refundable)

Credit Card orders
phone (916) 488-5350

The Musk Ox Company



- * Exceptional quality, rare hand-combed qiviut (underwool) from our own domesticated musk oxen—raw or ready to spin
- * Pure qiviut yarn in standard and lace weight
- * Exquisite hand-painted yarns of pure qiviut
- Send \$4.00 & legal SASE for brochure and fiber samples —
633 Fish Hatchery Road, Dept. 1, Hamilton, MT 59840
(406) 363-6818



Original Designs

Painter's Palette, Koigu Premium Merino
and Koigu 2-ply & 3-ply wool yarn.

Samples \$10-\$25 • Catalog \$5

R.R. #1, Williamsford, Ontario N0H 2V0 Canada
Phone/fax (519) 794-3066
email: koigu@hotmail.com

Exotic Natural Yarns, easy as . . .

- 1 Alpaca, llama, wool — dyed by the animals!
- 2 Handspun, hand-dyed mohair & wool
- 3 Original patterns & kits. Hard to find tools

Colour card & catalogue \$10, Rebate \$5 with order

Salt Spring Island 121 Mountain Road Tel: 250 653-4033
FIBRE Salt Spring Island, BC Fax: 250 537-9930
STUDIOS Canada • V8K 1T8 susanb@islandnet.com



Some call it string...
I call it sanity.
For you, it's a variety
of yarns up to
20%
off retail.

Trendsetters • Brown Sheep • Swedish Yarns • Dale of Norway
Berroco • Classic Elite • Renaissance and more
Catalog \$3.00 US, Refund with first order - Mail order only
810 22nd Avenue South, Moorhead, MN 56560 • 218-233-6670

Your Creations are Your
Yarn Expressions
come to us for project materials from

Alice Starmore	Classic Elite	Skacel Collection
Bartlett yarns	Dale of Norway	Tahki/Stahl
Berroco	Koigu Wools	Trendsetter
Brown Sheep	Plymouth Yarns	Unique Colours

we feature Michele Wyman patterns

ORDER LINE 1-800-283-8409

Yarn Expressions 7914 S. Memorial Pkwy. Huntsville, AL 35802

visa/master card/discover e-mail: mmanning@ro.com

Blackberry Ridge



Woolen Mill, Inc.

Wonderfully Soft Yarns from our Mill
Offering Yarns, Knitting Kits, and Patterns
New! Lace Shawl Kits and Patterns
by Hazel Carter

Free catalog listing yarns and products.
Yarn Samples \$3.00

Visit our web site at <http://www.blackberry-ridge.com>
3776 Forshaug Road Mt. Horeb, WI 53572
(608) 437-3762

Have you got a SECRET? . . .

stash of yarn!?

The Knitting Guild of Canada is looking for knitting nuts!

Any skill level, any kind of knitting.

Featuring Master Knitter Program, quarterly magazine, FUN!

Annual fee (including GST) only \$34 in Canada.

For mailing addresses outside Canada: \$34 U.S. funds.

Visa, MasterCard, checks accepted

For info: TKGC, Box 549, St. George, ON, Canada, N0E 1N0
tel 519-442-4150; fax 442-4673

Answer the call: KNITTERS UNITE!

The Knits Resource Guide

SPINNER'S HEARTH

Becky and Joe Scellato
7512 Lackey Rd., Vaughn, WA 98394
(253) 884-1500 • e-mail: spinners@narrows.com



FOR ALL YOUR KNITTING & SPINNING NEEDS

Alice Starmore • Annabel Fox • Berroco • Brown Sheep
Classic Elite • Creative • Crystal Palace • Cynthia Helene
Dale of Norway • Green Mountain • Manos • Mountain Colors
Muench • Patons • Peer Gynt • Plymouth
Philosopher's Wool • Tahki/Stahl

Lots of kits - Socks, Shawls, Vests & Sweaters

Join our Sock-of-the-Month Club and
Manos Afghan Square-of-the-Month Club

NATURAL FIBER YARNS

including ROWAN, TAHKI, VITTADINI,
ELITE, REYNOLDS, PHILDAR, etc.

Plus first-quality mill ends



Send \$5.25 for complete mail order sample card of over
500 colors and textures

Periodic Updates • Quantity Discounts

Also Available: Exotic fiber sample card, approx. 150 samples of silks,
angoras, ribbons & exotics. \$2.75

Bare Hill Studios/Fiber Loft (retail)

Box 327, Rt. 111 (P.O. Bldg), Harvard MA 01451 • 1-800-874-YARN

ADDI • BRITTANY • CRYSTAL PALACE
NEEDLES & HOOKS

Free Price List Available

Garden City Stitches
FINE YARN • NEEDLEWORK

725 FRANKLIN AVENUE
GARDEN CITY, NY 11530

(516)739.KNIT
5648



**Experience
knitting with our
soft wool yarn!**

Carefully washed in a non-caustic solution and then softly spun to retain
its natural characteristics. Over 50 lovely heather tones, two-toned
marls, and vibrant Shetland colors. Worsted, sportweight & bulky.
Affordable price for 4-oz. skeins. Order directly from our sheep farm.

1186 Jarvis Branch Rd., Mars Hill, NC 28754, 704-689-9931

Yarn samples \$3. Refundable with order. MC/VISA

DESIGN SOFTWARE

• Garment Styler

for knitting instructions & sewing patterns \$85.

• Stitch Painter

for gridded knit & craft design \$85./\$165.

Cochenne Design Studio
P.O. Box 4276 - C,
Encinitas, CA 92023-4276
(619) 259-1698

Windows & Macintosh

catalogue \$1.
<http://www.cochenne.com>



**General Bailey
Homestead Farm**

Featuring top quality products at reasonable prices.

Needles • Buttons • Books • Patterns
Yarn • Jewelry • Dyes • Exotics

Try our new super-size 13³/₄" x 18"
Knitter's Graph Paper—20 sheets \$8.50 ppd.

New '98 Catalog \$2.00 (available 4-1-98)

340 Spier Falls Road • Greenfield Center, NY 12833-2005

(518) 893-2015

VISA • MASTERCARD • DISCOVER

Interweave
Knits

**Your Directory Ad
Could Be Here!!!**

This is the readership you have been looking for!

Call Knits Advertising Dept. (800) 272-2193

for more information

RAVELINGS

Linda Ligon



WHAT I WANT TO KNOW is how women in the Andes learned to knit. I don't mean as a cultural thing, but as individuals. And I don't mean how to do knit-purl, but how to make intricate sweaters and shawls from every knitting tradition imaginable, with no recorded patterns.

I've travelled in Bolivia and Peru in recent years, and being a knitter, one of the first things I've noticed is that everybody wears great-looking wool sweaters. And I do mean everybody. This is not a



class thing. Traditional women in hand-woven skirts and odd black derbies with babies on their backs also wear under their traditional ruanas, cabled pullovers with intricate decreases. Men in rubber-tire sandals, cotton pants, and handspun ponchos pushing wagon loads of produce also sport handsome ganseys and GQ-worthy alpaca cardigans. Travelling stitches, intarsia, argyle, fancy ribs—you see it all on the streets and in the markets of Cusco or LaPaz.

You also see these items being made. Women tending market stalls and minding a flock of children are knitting. Women on park benches peddling odds and ends are knitting. Women on cathedral steps with baby llamas or lambs wrapped in their shawls, waiting for tourists with cameras, are knitting. They're knitting out of their

heads, or maybe just out of their hands, without looking, without referring to patterns. They're knitting while making conversation or making change. They're knitting intricate circular lace shawls, sweaters, vests, baby caps, socks. They're using handspun natural wool, llama, or alpaca, or they're using gaudy acrylics.

Now, I know there are a lot of European traditions that involve prolific, facile knitting—the color-stranded sweaters of Scandinavia, the fisherman sweaters of the Channel Isles, the socks and gloves of Northern England. There, women (and sometimes men) also knitted automatically with ease while sauntering about or whatever. The difference, as I see it, is they knitted only one kind of thing. Knitters had their own variations on the standard, but if a traditional Aran knitter suddenly abandoned her intricate cabled pullovers in favor of brightly patterned cropped boleros, I haven't heard about it.



Travelling Stitches

The women of the Andean altiplano, on the other hand, adopt all styles with wild abandon. They do have a long-standing knitting tradition, it's true—but it mostly involves fine, fine color-patterned caps in either handspun cotton or wool with earflaps and a pointed, tasseled crown. You expect to see and marvel over those. Yet I also saw, for instance, an elderly woman on a street corner in LaPaz doing an entrelac sweater in bright pink and lime green. Where did she learn this? What was she thinking? And where did younger mothers pick up the trick of knitting kinky-spiraled pigtail bows for their little girls, just like the ones you find at craft bazaars here? And how do the lace shawl knitters keep track of their yarn-overs while weighing chicken giblets in the markets? Did their grandmothers teach them lace knitting?

I don't know the answers; maybe you do. It's wonderfully paradoxical, though, to see such lighthearted, enthusiastic innovation in a culture where fields are still planted by oxen and transportation is more likely to be by burro than by automobile. And it's awe-inspiring to see it all happen so intuitively and skillfully. ∞

Linda Ligon is editorial director of Interweave Knits. She's grateful that she's not trying to publish a knitting-pattern magazine in South America. After all, who would need it?

ROVINGS

Custom Carding and Dyeing of
fine wools and exotic fibres.



SILKS! ALPACA! ANGORA! KID MOHAIR!

These exotic fibres are blended with Prime
Australian Polwarth wool into 6 luxurious yarns.

42 Gorgeous hand-dyed colours.

We colour match to your specifications.

Polwarth and Polwarth blend yarns—

Hand-dyed or natural colors.

Price list available upon request.

Sample cards \$10.00

Shop Hours: Tuesday - Friday 10:00 - 5:00 (CST)

Saturday 10:00 - 1:00

Box 192 Oakbank, MB Canada R0E 1J0

1-800-266-5536

fax: 1-204-444-2245

Visa/MC accepted

Prices are in Canadian Dollars



*It's daddy's night tonight,
walking and snuggling
...then drifting off
to dreamland in
baby's little blanket.*

 **Patons**

Patons Yarns...part of your life.

PATONS LITTLE ME BABY SPORT YARN AND PATTERN BOOK 753 ARE
AVAILABLE NOW, AT WELL STOCKED YARN STORES. • WWW.COATSPATONS.COM